

Contents

Geometric Shapes	G1 - G9
Miscellaneous Standards	M1 - M6
Architectural Systems	A1 - A3

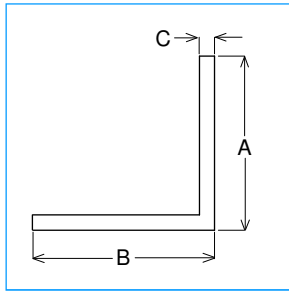

Angle

Part #	A (mm)	B (mm)	C (mm)	Mass (kg/m)	Int. Rad.	Ext. Rad.
EA0176	20.00	12.00	1.40	0.116		
EA0101	20.00	12.00	1.60	0.131		
EA0115	20.00	20.00	1.40	0.146		
EA0082	20.00	20.00	3.00	0.300		
EA0177	25.00	12.00	1.40	0.135		
EA0041	25.00	12.00	3.00	0.275		
EA0123	25.00	20.00	1.40	0.165		
EA0100	25.00	20.00	1.60	0.188		
EA0124	25.00	20.00	3.00	0.340		
EA0030	25.00	25.00	1.40	0.184		
EA0027	25.00	25.00	1.60	0.209		
EA0031	25.00	25.00	3.00	0.381		
EA0116	25.00	25.00	6.00	0.713		
EA0029	32.00	20.00	1.40	0.191		
EA0232	32.00	20.00	1.60	0.218		
EA1002	32.00	20.00	3.00	0.397		
EA0178	32.00	25.00	3.00	0.437		
EA0188	32.00	32.00	1.40	0.237		
EA0117	32.00	32.00	3.00	0.494		
EA0189	40.00	12.00	1.40	0.191		
EA0179	40.00	20.00	1.40	0.222		
EA0162	40.00	20.00	1.60	0.252		
EA0166	40.00	20.00	3.00	0.462		
EA0230	40.00	25.00	1.50	0.257		
EA0028	40.00	40.00	1.40	0.297		
EA0068	40.00	40.00	3.00	0.624		
EA0118	40.00	40.00	4.00	0.821		
EA0119	40.00	40.00	6.00	1.199		
EA0048	48.00	43.25	1.60	0.387		
EA0182	50.00	20.00	3.00	0.543		

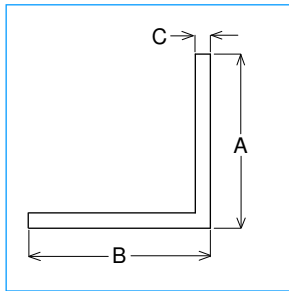

Angle Continued

Part #	A (mm)	B (mm)	C (mm)	Mass (kg/m)	Int. Rad.	Ext. Rad.
EA0213	50.00	25.00	1.40	0.278		
EA0244	50.00	25.00	3.00	0.583		
EA0120	50.00	50.00	1.40	0.373		
EA0242	50.00	50.00	1.60	0.425		
EA0241	50.00	50.00	2.50	0.658		
EA0045	50.00	50.00	3.00	0.785		
EA0209	50.00	50.00	4.00	1.037		
EA0043	50.00	50.00	6.00	1.522		
EA0159	60.00	25.00	3.00	0.664		
EA0199	60.00	40.00	4.00	1.037		
EA0175	60.00	60.00	3.00	0.948		
EA0239	70.00	40.00	1.60	0.468		
EA0121	76.00	76.00	3.00	1.207		
EA0169	80.00	20.00	3.00	0.786		
EA0122	80.00	80.00	6.00	2.495		
EA0190	100.00	50.00	4.00	1.577		
EA0133	125.00	50.00	3.00	1.393		
EA0250	125.00	50.00	6.00	2.743	3.00	

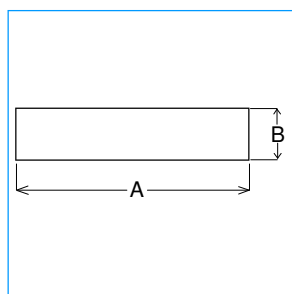

Flat Bar

Part #	A (mm)	B (mm)	C (mm)	Mass (kg/m)	Int. Rad.	Ext. Rad.
EA0093	20.00	3.00		0.162		
EA0110	20.00	6.00		0.324		
EA0216	20.00	10.00		0.540		
EA0026	25.00	3.00		0.203		
EA0237	25.00	5.00		0.338		
EA0111	25.00	6.00		0.405		
EA0086	32.00	3.00		0.259		
EA0112	32.00	6.00		0.518		
EA0243	32.00	10.00		0.864		
EA0091	35.00	1.50		0.142		
EA0109	40.00	3.00		0.324		
EA0246	40.00	4.00		0.431		
EA0113	40.00	6.00		0.648		
EA0170	40.00	10.00		1.080		
EA0236	40.00	12.00		1.296		
EA0206	40.00	25.00		2.700		
EA0207	45.00	3.00		0.365		
EA0156	50.00	3.00		0.405		
EA0042	50.00	6.00		0.810		
EA0234	50.00	8.00		1.080		
EA0105	50.00	10.00		1.350		
EA0174	50.00	20.00		2.700		
EA0106	50.00	25.00		3.375		
EA0025	60.00	6.00		0.972		
EA0097	80.00	3.00		0.648		
EA0114	80.00	6.00		1.296		
EA0076	80.00	10.00		2.160		
EA0102	80.00	12.00		2.592		
EA0168	80.00	16.00		3.456		
EA0107	80.00	25.00		5.400		

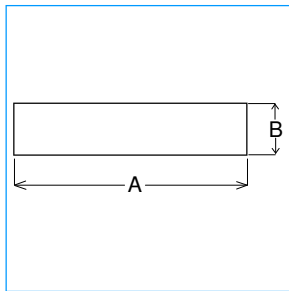

Flat Bar Continued

Part #	A (mm)	B (mm)	C (mm)	Mass (kg/m)	Int. Rad.	Ext. Rad.
EA0235	89.00	6.00		1.442		
EA0033	100.00	1.50		0.405		
EA0108	100.00	3.00		0.810		
EA0090	100.00	6.00		1.620		
EA0103	100.00	10.00		2.700		
EA0173	100.00	12.00		3.240		
EA0088	100.00	25.00		6.750		
EA0104	160.00	10.00		4.320		

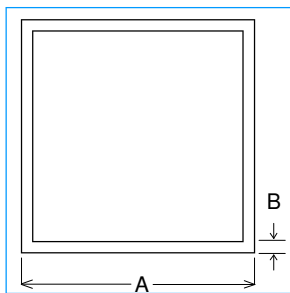

Square Hollow

Part #	A (mm)	B (mm)	C (mm)	Mass (kg/m)	Int. Rad.	Ext. Rad.
EA0134	19.15	1.73		0.326	1.57	1.57
EA0135	20.00	2.50		0.473		
EA0233	20.00	3.00		0.530		3.00
EA0063	25.00	1.60		0.404		
EA0214	25.00	1.60		0.390		2.50
EA0079	25.00	2.00		0.497		
EA0092	25.00	3.00		0.713		
EA0231	25.00	3.00		0.713	3.00	3.00
EA0140	25.30	3.20		0.743		3.00
EA0085	25.40	1.22		0.319		
EA0136	32.00	3.00		0.940		
EA0223	40.00	1.60		0.664		
EA0253	40.00	1.60		0.652	2.00	3.00
EA0137	40.00	2.50		1.013		
EA1066	40.00	3.00		1.199		
EA0254	40.00	3.00		1.187	2.00	3.00
EA0046	50.00	2.50		1.283		
EA0138	50.00	3.00		1.523		
EA0238	50.00	1.60		0.798	4.40	6.00
EA0158	50.80	1.60		0.812	4.40	6.00
EA0139	65.00	1.60		1.096		
EA0145	98.00	2.50		2.578		

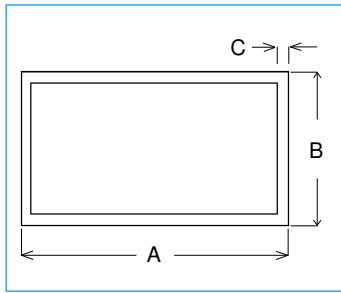

Rectangular Hollow

Part #	A (mm)	B (mm)	C (mm)	Mass (kg/m)	Int. Rad.	Ext. Rad.
EA0226	25.40	19.05	1.00	0.229		
EA0215	40.00	20.00	3.00	0.875		
EA0142	40.00	25.00	2.50	0.810		
EA0143	50.00	25.00	2.50	0.945		
EA0095	50.00	25.00	3.00	1.118		
EA0224	50.00	38.00	3.00	1.328		
EA0251	60.00	20.00	1.60	0.664		
EA0171	60.00	40.00	3.00	1.523		
EA0200	65.00	16.00	1.40	0.580	2.00	3.00
EA0270	65.20	16.30	1.20	0.499	1.80	3.00
EA0219	75.00	25.00	2.20	1.136		
EA0187	75.00	50.00	3.00	1.928		
EA0210	76.00	25.00	1.50	0.794		
EA0186	76.20	38.10	3.18	1.853		
EA0067	80.00	40.00	3.00	1.847		
EA0183	80.00	50.00	3.00	2.009		
EA0204	82.28	28.58	2.20	1.265		
EA0071	100.00	25.00	2.50	1.620		
EA0229	100.00	40.00	2.00	1.469		
EA0245	100.00	50.00	1.50	1.191		
EA0141	100.00	50.00	3.00	2.333		
EA0208	125.00	50.00	3.00	2.738		
EA0228	140.00	50.00	2.20	2.205		
EA0181	150.00	50.00	3.00	3.143		
EA0157	200.00	50.00	3.00	3.953		

TRIPLE HOLLOW

EA0024	39.00	10.00	1.90	0.525		1.00
--------	-------	-------	------	-------	--	------

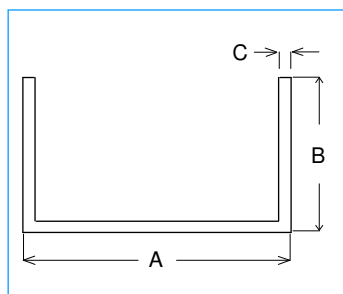

Channel

Part #	A (mm)	B (mm)	C (mm)	Mass (kg/m)	Int. Rad.	Ext. Rad.
EA0078	20.00	16.00	1.60	0.211		
EA0077	20.00	20.00	1.60	0.245		
EA0180	20.00	20.00	3.00	0.437		
EA0034	25.00	20.00	2.50	0.405		
EA0126	25.00	25.00	1.60	0.310		
EA0032	25.00	25.00	3.00	0.559		
EA0129	25.00	40.00	3.00	0.802		
EA0130	32.00	25.00	3.00	0.616		
EA0225	32.00	40.00	3.00	0.859		
EA0131	40.00	25.00	3.00	0.681		
EA0069	40.00	40.00	3.00	0.923		
EA0047	49.60	66.4 / 43.6	1.60	0.675		
EA0080	50.00	25.00	3.00	0.761		
EA0127	50.00	50.00	3.00	1.166		
EA0087	60.00	32.00	3.00	0.956		
EA0066	80.00	25.00	3.00	1.005		
EA0044	80.00	40.00	3.00	1.247		
EA0132	80.00	40.00	4.00	1.642		
EA0099	100.00	25.00	3.00	1.166		
EA0128	100.00	40.00	3.00	1.409		
EA0163	100.00	40.00	4.00	1.858		
EA0198	100.00	50.00	3.00	1.571		

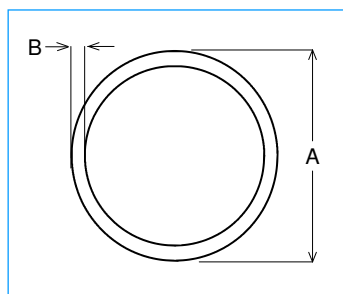

Round Tube

Part #	A (mm)	B (mm)	C (mm)	Mass (kg/m)	Int. Rad.	Ext. Rad.
EA0027	12.65	1.00		0.099		
EA1013	15.90	1.40		0.173		
EA0070	16.00	1.60		0.195		
EA0252	19.05	1.65		0.243		
EA0081	20.00	1.60		0.250		
EA1003	25.00	1.20		0.243		
EA1001	25.00	1.60		0.318		
EA0062	25.00	3.00		0.568		
EA0146	32.00	1.60		0.413		
EA0147	32.00	3.00		0.738		
EA0172	38.00	2.00		0.611		
EA0148	40.00	3.00		0.942		
EA0155	50.00	1.60		0.657		
EA0072	50.00	3.00		1.196		
EA0053	60.00	2.00		0.984		
EA0165	60.00	5.00		2.333		
EA0049	63.50	6.00		2.926		
EA1089	76.20	3.80		2.334		
EA0184	80.00	2.00		1.323		
EA1901	100.40	2.30		1.914		
EA0247	120.00	3.00		2.980		
EA1902	125.00	3.00		3.105		
EA0248	140.00	3.00		3.486		

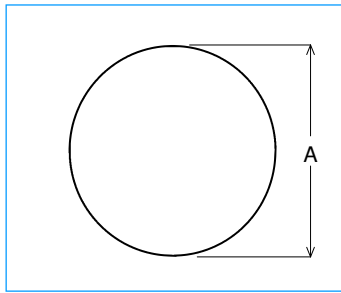

Rod

Part #	A (mm)	B (mm)	C (mm)	Mass (kg/m)	Int. Rad.	Ext. Rad.
EA0074	8.00			0.136		
EA0075	10.00			0.212		
EA0164	18.00			0.687		

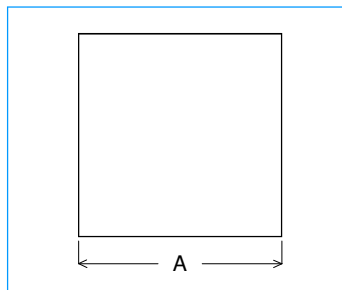

Square Bar

Part #	A (mm)	B (mm)	C (mm)	Mass (kg/m)	Int. Rad.	Ext. Rad.
EA0211	40.00			4.320		
EA0212	50.00			6.750		
EA0089	65.00			11.408		

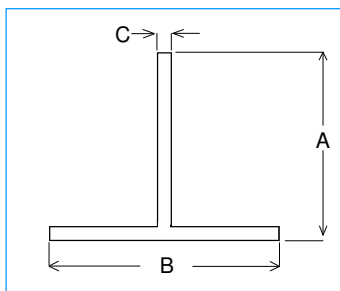

T Section

Part #	A (mm)	B (mm)	C (mm)	Mass (kg/m)	Int. Rad.	Ext. Rad.
EA0149	20.00	20.00	3.00	0.300		
EA0055	25.00	25.00	3.00	0.381		
EA0150	40.00	40.00	1.60	0.339		
EA0185	40.00	40.00	3.00	0.624		
EA0037	44.45	38.10	1.58	0.346		

Adaptor

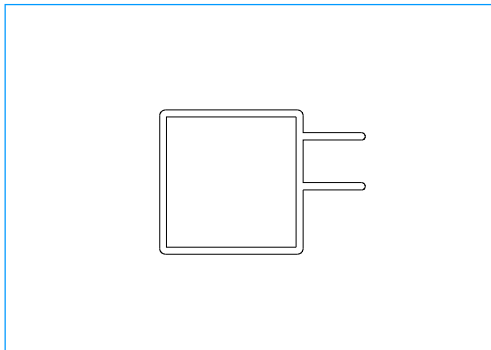

Part #	A (mm)	B (mm)	Mass (kg/m)
--------	--------	--------	-------------

EA0098	25.40	1.22	0.393
--------	-------	------	-------

Single Rub Rail

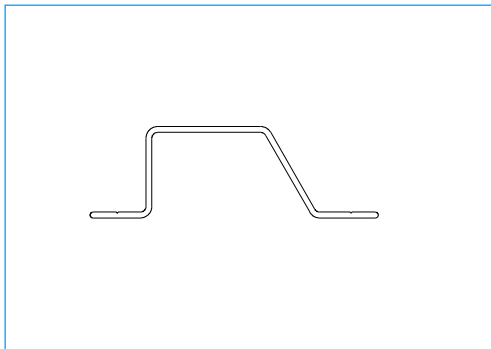

EA0160	74.20	23.40	0.429
--------	-------	-------	-------

Double Rub Rail

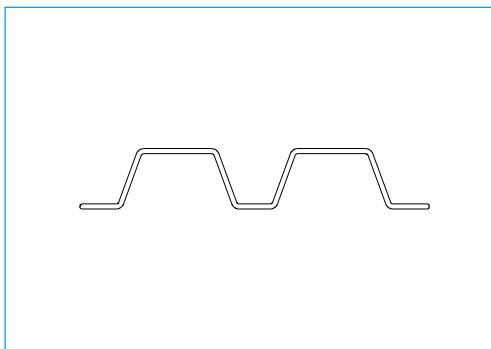

EA0161	110.00	19.00	0.674
--------	--------	-------	-------

Sign Box

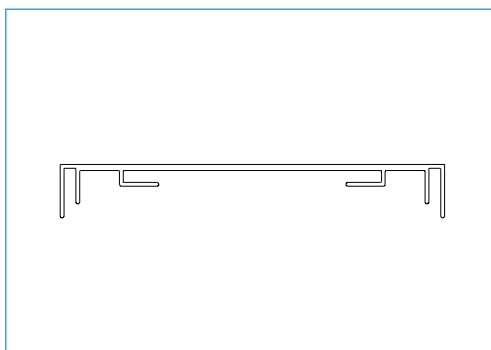

EA0218	195.00	27.00	2.272
--------	--------	-------	-------

Slatwall

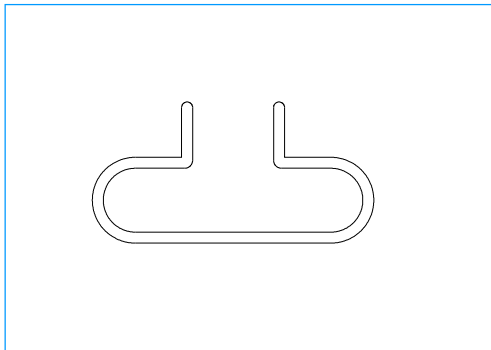

Part #	A (mm)	B (mm)	Mass (kg/m)
--------	--------	--------	-------------

EA0052	28.18	14.14	0.194
--------	-------	-------	-------

Slatwall

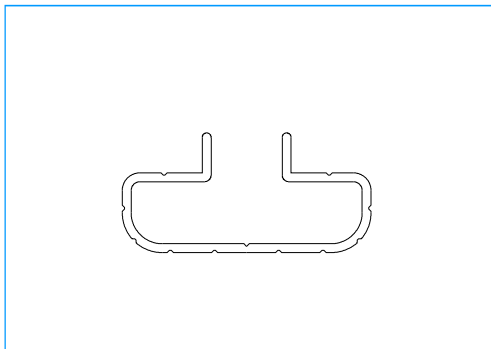

EA0220	28.00	9.00	0.174
--------	-------	------	-------

Base Channel

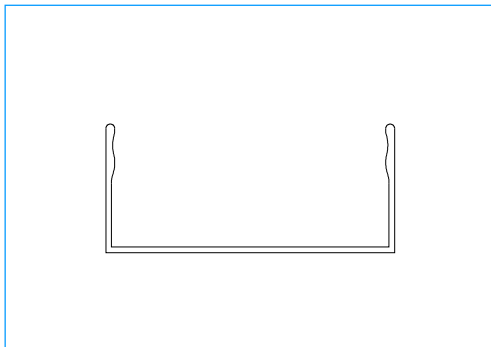

EA0151	81.00	36.00	0.682
--------	-------	-------	-------

Base Channel

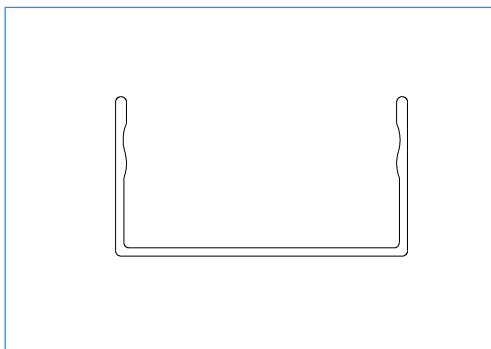

EA0152	55.10	30.06	0.494
--------	-------	-------	-------

Single Flanged Rope Track

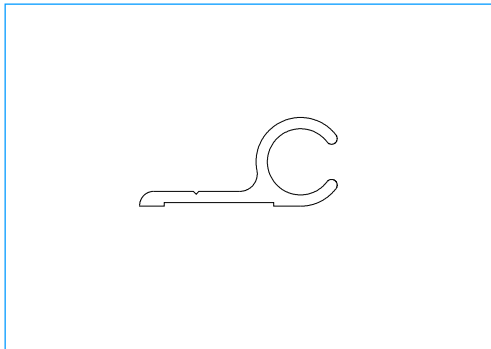

Part #	A (mm)	B (mm)	Mass (kg/m)
--------	--------	--------	-------------

EA0051	28.00	12.60	0.219
--------	-------	-------	-------

Double Flanged Rope Track

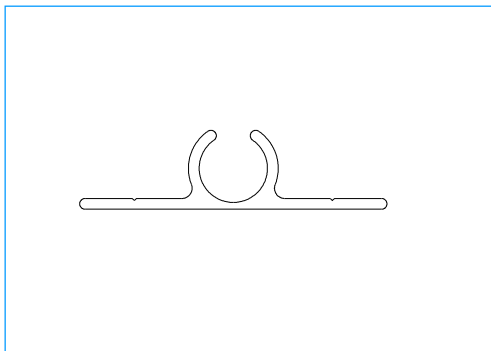

EA0217	45.00	11.55	0.289
--------	-------	-------	-------

Windscreen Mould

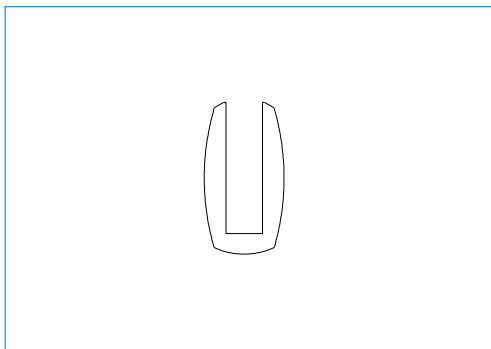

EA0154	22.23	11.70	0.347
--------	-------	-------	-------

Bullnose Stair Tread

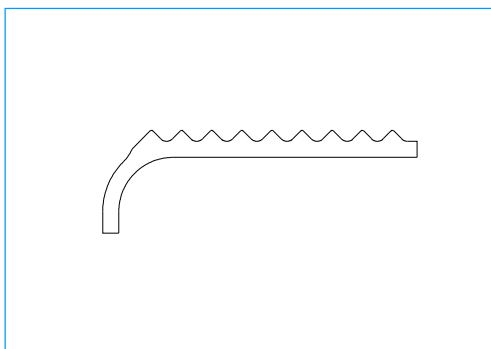

EA0167	46.02	15.06	0.420
--------	-------	-------	-------

Caravan Angle

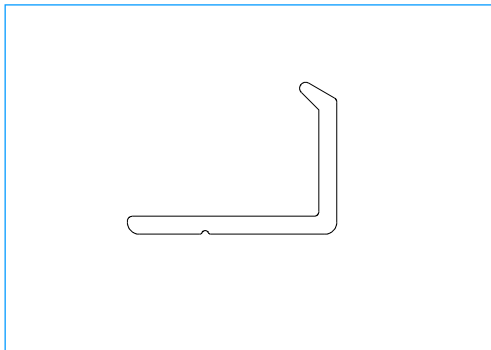

Part #	A (mm)	B (mm)	Mass (kg/m)
--------	--------	--------	-------------

EA0222	17.50	12.70	0.116
--------	-------	-------	-------

Caravan Trim—J

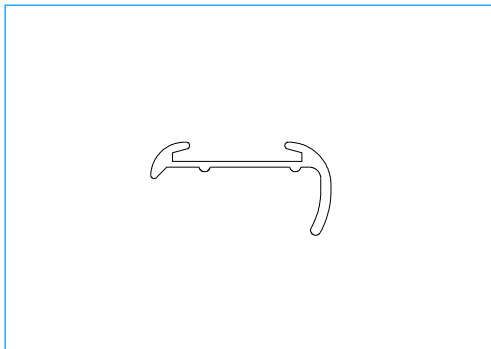

EA0197	31.79	16.40	0.216
--------	-------	-------	-------

Caravan Trim—Flat

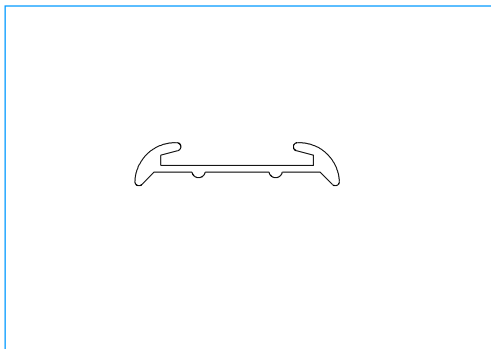

EA0221	30.50	6.40	0.161
--------	-------	------	-------

Racking Material

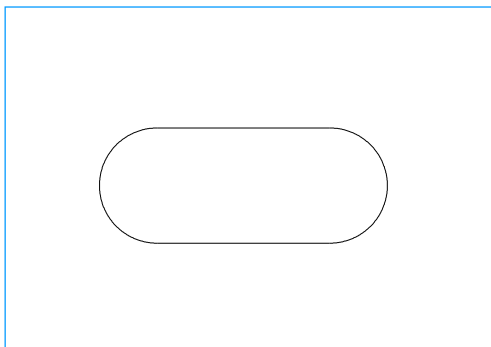

EA0038	25.00	10.00	0.618
--------	-------	-------	-------

Racking Material

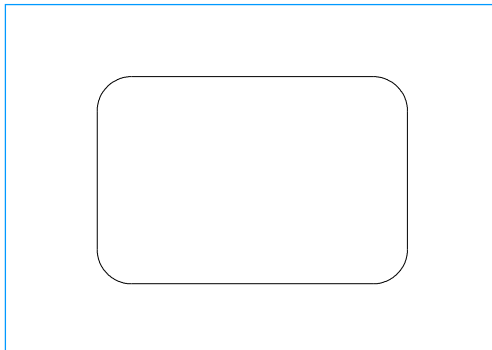

Part #	A (mm)	B (mm)	Mass (kg/m)
--------	--------	--------	-------------

EA0039	45.00	30.00	3.587
--------	-------	-------	-------

Racking Material

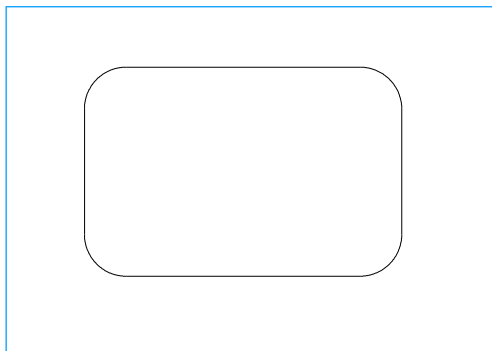

EA0040	38.00	25.00	2.507
--------	-------	-------	-------

75mm Coving

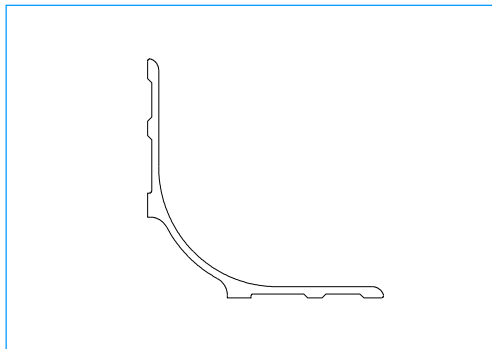

EA0202	75.00	75.00	0.682
--------	-------	-------	-------

50mm Coving

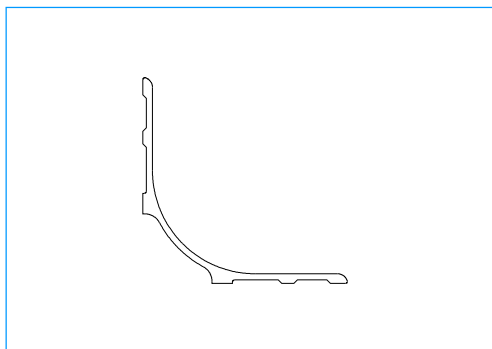

EA0203	50.00	50.00	0.447
--------	-------	-------	-------

75mm Coolroom Corner

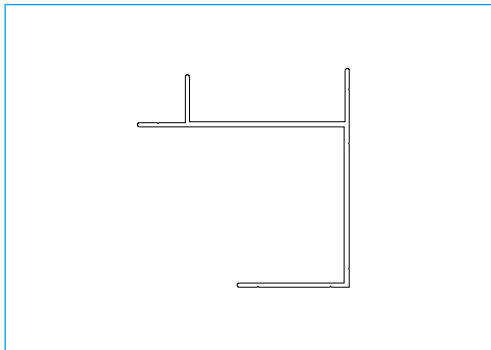

Part #	A (mm)	B (mm)	Mass (kg/m)
--------	--------	--------	-------------

EA0205	75.00		1.707
--------	-------	--	-------

F Section

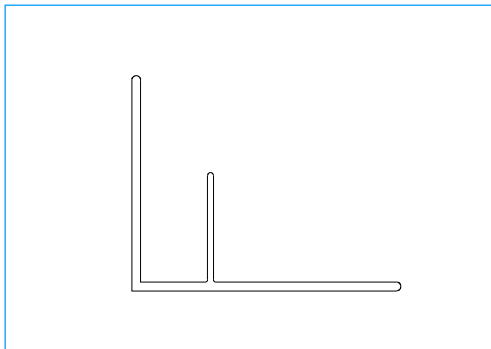

EA0249	60.10	48.20	0.658
--------	-------	-------	-------

Ballustrade Handrail

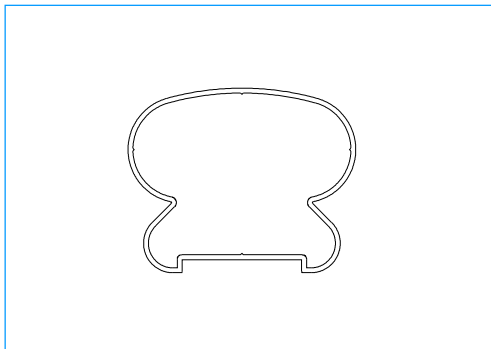





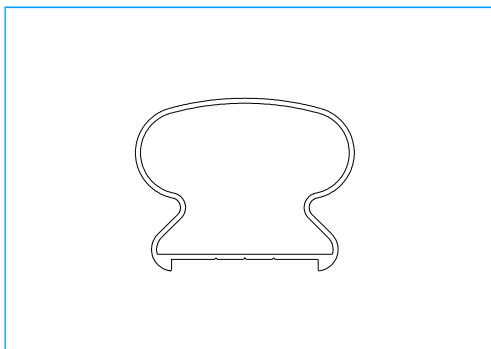





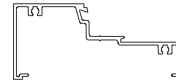

EA0256	82.10	1.75	1.328
--------	-------	------	-------

Ballastrade Handrail Insert

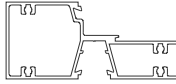

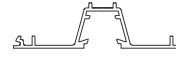

EA0255	76.00	60.00	1.267
--------	-------	-------	-------



101.6 x 44.4 mm Centre Glazed. Standard Pocket (15mm)

 Heavy Frame EA0001	 Standard Frame EA0002	 Light Frame EA0003	 Light Frame (2) EA0096	 Standard Sill EA0004
 Heavy Duty Self-Mating Mullion EA0008	 Heavy Duty Sill EA0015	 Glazing Adaptor EA0005	 Heavy Duty Glazing Adaptor EA0240	 Glazing Adaptor (2) EA0050
 Flat Filler EA0018	 Sill Bead EA0006	 Door Stop EA0007	 Pocket Filler EA0083	

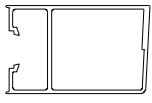
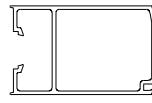
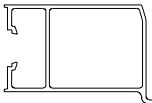
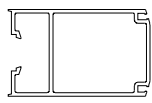
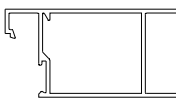
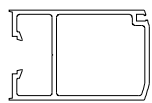
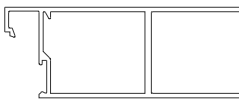
Standard 45mm Hinged and Sliding Doors. Single Glazed

 Plain Stile EA0260	 Sliding Door Stile EA0261	 Hinge Stile EA0258	 Lock Stile EA0257	 Meeting Stile EA0262
 Weather Stile EA0263	 Top Rail EA0264	 Lock Stile (Heavy) EA0061	 Bottom Rail EA0265	

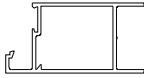
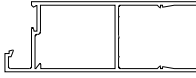
400 Series Door Suite, Single Glazed

			
Top Rail EA0009	Bottom Rail EA0010	Sash Bead EA0011	Mid Rail EA0012

Wide Hinged and Sliding Doors (114mm). Single Glazed



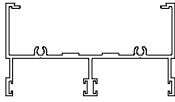
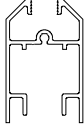
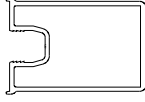
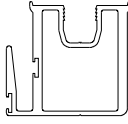
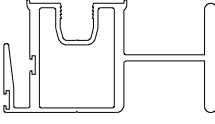

				
Sliding Stile EA0266	Hinge Stile EA0267	Lock Stile EA0268	Pivot Stile EA0269	Bottom Rail EA0265

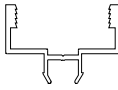
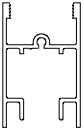
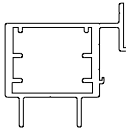
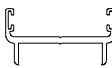
Apartment Door Suite

				
Head/Jamb EA1004 (101.6mm suites)	Door Rail EA1005	Plain Stile EA1006	Interlock EA1007	Interlock EA1008

			
DB Glaze Adaptor EA1009	Door Rail EA1010	Adaptor EA1011	Adaptor EA1012

103.6 x 50mm Front Glazed. Single Glazed. Capped

				
Head/Jamb EA0201	Male Split Mullion EA0019	Female Split Mullion EA0020	Adaptor EA0021	Snap Cover EA0022

Snap Cover EA0023



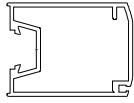
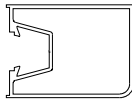

45mm Hinged and Sliding Doors. Single Glazed

	
Lock Stile EA0013	Hinge Stile EA0014

Ballustrade

				
Handrail EA0256	Handrail Insert EA0255	Fence Rail (Heavy) EA0254	Fence Rail (Light) EA0253	Round Picket EA0252

Miscellaneous

			
Security Door Frame EA0144	Awning Sash (50 mm) EA0054	Narrow Frame (101.6 x 25 mm) EA0016	Frame (101.6 x 50 mm) EA0084