

Angle

| Part # | A (mm) | B (mm) | C (mm) | Mass (kg/m) | Int. Rad. | Ext. Rad. |
|--------|--------|--------|--------|-------------|-----------|-----------|
| EA0280 | 16.00 | 16.00 | 1.50 | 0.124 | | |
| EA2655 | 24.00 | 6.00 | 1.60 | 0.105 | | |
| EA0176 | 20.00 | 12.00 | 1.40 | 0.116 | | |
| EA0101 | 20.00 | 12.00 | 1.60 | 0.131 | | |
| EA0115 | 20.00 | 20.00 | 1.40 | 0.146 | | |
| EA4014 | 20.00 | 20.00 | 1.60 | 0.166 | | |
| EA0082 | 20.00 | 20.00 | 3.00 | 0.300 | | |
| EA0177 | 25.00 | 12.00 | 1.40 | 0.135 | | |
| EA0041 | 25.00 | 12.00 | 3.00 | 0.275 | | |
| EA0123 | 25.00 | 20.00 | 1.40 | 0.165 | | |
| EA0100 | 25.00 | 20.00 | 1.60 | 0.188 | | |
| EA0124 | 25.00 | 20.00 | 3.00 | 0.340 | | |
| EA0030 | 25.00 | 25.00 | 1.40 | 0.184 | | |
| EA0027 | 25.00 | 25.00 | 1.60 | 0.209 | | |
| EA0031 | 25.00 | 25.00 | 3.00 | 0.381 | | |
| EA0116 | 25.00 | 25.00 | 6.00 | 0.713 | | |
| EA3316 | 30.00 | 30.00 | 1.60 | 0.252 | | |
| EA0281 | 32.00 | 12.00 | 3.00 | 0.332 | | |
| EA0282 | 32.00 | 20.00 | 1.50 | 0.205 | | |
| EA0029 | 32.00 | 20.00 | 1.40 | 0.191 | | |
| EA0232 | 32.00 | 20.00 | 1.60 | 0.218 | | |
| EA1002 | 32.00 | 20.00 | 3.00 | 0.397 | | |
| EA0178 | 32.00 | 25.00 | 3.00 | 0.437 | | |
| EA0472 | 32.00 | 25.00 | 5.00 | 0.702 | | |
| EA0188 | 32.00 | 32.00 | 1.40 | 0.237 | | |
| EA0117 | 32.00 | 32.00 | 3.00 | 0.494 | | |
| EA0483 | 35.00 | 35.00 | 1.60 | 0.295 | | |
| EA0189 | 40.00 | 12.00 | 1.40 | 0.191 | | |
| EA0179 | 40.00 | 20.00 | 1.40 | 0.222 | | |
| EA0162 | 40.00 | 20.00 | 1.60 | 0.252 | | |
| EA0166 | 40.00 | 20.00 | 3.00 | 0.462 | | |

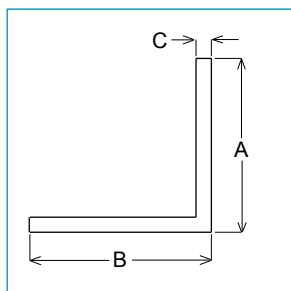

Angle Continued

| Part # | A (mm) | B (mm) | C (mm) | Mass (kg/m) | Int. Rad. | Ext. Rad. |
|--------|--------|--------|--------|-------------|-----------|-----------|
| EA0230 | 40.00 | 25.00 | 1.50 | 0.257 | | |
| EA0307 | 40.00 | 25.00 | 3.00 | 0.502 | | |
| EA0028 | 40.00 | 40.00 | 1.40 | 0.297 | | |
| EA0068 | 40.00 | 40.00 | 3.00 | 0.624 | | |
| EA0118 | 40.00 | 40.00 | 4.00 | 0.821 | | |
| EA0119 | 40.00 | 40.00 | 6.00 | 1.199 | | |
| EA3269 | 47.00 | 32.00 | .000 | 0.615 | | |
| EA0048 | 48.00 | 43.25 | 1.60 | 0.387 | | |
| EA0439 | 50.00 | 12.00 | 3.00 | 0.478 | | |
| EA0182 | 50.00 | 20.00 | 3.00 | 0.543 | | |
| EA0213 | 50.00 | 25.00 | 1.40 | 0.278 | | |
| EA0446 | 50.00 | 25.00 | 1.60 | 0.317 | | |
| EA0244 | 50.00 | 25.00 | 3.00 | 0.583 | | |
| EA0120 | 50.00 | 50.00 | 1.40 | 0.373 | | |
| EA0242 | 50.00 | 50.00 | 1.60 | 0.425 | | |
| EA0241 | 50.00 | 50.00 | 2.50 | 0.658 | | |
| EA0045 | 50.00 | 50.00 | 3.00 | 0.786 | | |
| EA0209 | 50.00 | 50.00 | 4.00 | 1.037 | | |
| EA0043 | 50.00 | 50.00 | 6.00 | 1.522 | | |
| EA3442 | 56.10 | 23.50 | 3.00 | 0.622 | | |
| EA0159 | 60.00 | 25.00 | 3.00 | 0.664 | | |
| EA0199 | 60.00 | 40.00 | 4.00 | 1.037 | | |
| EA0175 | 60.00 | 60.00 | 3.00 | 0.948 | | |
| EA0437 | 60.00 | 60.00 | 6.00 | 1.846 | | |
| EA0434 | 70.00 | 25.00 | 1.50 | 0.378 | | |
| EA0239 | 70.00 | 40.00 | 1.60 | 0.468 | | |
| EA2858 | 75.00 | 35.00 | 3.00 | 0.866 | | |
| EA2782 | 75.00 | 75.00 | 2.50 | 0.995 | | |
| EA0121 | 76.00 | 76.00 | 3.00 | 1.207 | | |
| EA0169 | 80.00 | 20.00 | 3.00 | 0.786 | | |
| EA0469 | 80.00 | 40.00 | 6.00 | | | |

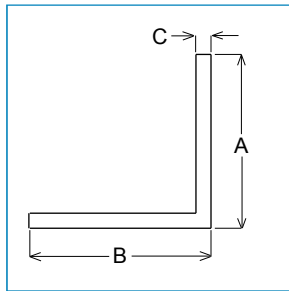

Angle Continued

| Part # | A (mm) | B (mm) | C (mm) | Mass (kg/m) | Int. Rad. | Ext. Rad. |
|--------|--------|--------|--------|-------------|-----------|-----------|
| EA0122 | 80.00 | 80.00 | 6.00 | 2.495 | | |
| EA0482 | 80.00 | 80.00 | 10.00 | 4.086 | 6.00 | |
| EA0324 | 90.00 | 25.00 | 3.00 | 0.907 | | |
| EA0273 | 90.00 | 40.00 | 1.60 | 0.555 | | |
| EA0283 | 100.00 | 25.00 | 1.50 | 0.500 | | |
| EA0323 | 100.00 | 25.00 | 1.60 | 0.533 | | |
| EA0475 | 100.00 | 50.00 | 3.00 | 1.190 | | |
| EA0190 | 100.00 | 50.00 | 4.00 | 1.577 | | |
| EA0484 | 100.00 | 50.00 | 6.00 | 2.332 | | |
| EA0286 | 100.00 | 100.00 | 6.00 | 3.140 | | |
| EA0133 | 125.00 | 50.00 | 3.00 | 1.393 | | |
| EA0250 | 125.00 | 50.00 | 6.00 | 2.743 | 3.00 | |

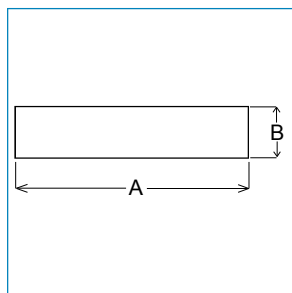

Flat Bar

| Part # | A (mm) | B (mm) | C (mm) | Mass (kg/m) | End Rad. | |
|--------|--------|--------|--------|-------------|----------|------|
| EA0093 | 20.00 | 3.00 | | 0.162 | | |
| EA0110 | 20.00 | 6.00 | | 0.324 | | |
| EA0216 | 20.00 | 10.00 | | 0.540 | | |
| EA0026 | 25.00 | 3.00 | | 0.203 | | |
| EA0237 | 25.00 | 5.00 | | 0.338 | | |
| EA0111 | 25.00 | 6.00 | | 0.405 | | |
| EA0416 | 25.00 | 10.00 | | 0.675 | | |
| EA0086 | 32.00 | 3.00 | | 0.259 | | |
| EA0427 | 32.00 | 5.00 | | 0.432 | | |
| EA0112 | 32.00 | 6.00 | | 0.518 | | |
| EA0243 | 32.00 | 10.00 | | 0.864 | | |
| EA0091 | 35.00 | 1.50 | | 0.142 | | |
| EA0109 | 40.00 | 3.00 | | 0.324 | | |
| EA0246 | 40.00 | 4.00 | | 0.431 | | |
| EA0432 | 40.00 | 5.00 | | 0.540 | | |
| EA0113 | 40.00 | 6.00 | | 0.648 | | |
| EA0170 | 40.00 | 10.00 | | 1.080 | | |
| EA0236 | 40.00 | 12.00 | | 1.296 | | |
| EA0206 | 40.00 | 25.00 | | 2.700 | | |
| EA0207 | 45.00 | 3.00 | | 0.365 | | |
| EA0445 | 45.00 | 5.00 | | 0.607 | | |
| EA0295 | 50.00 | 1.50 | | 0.202 | | |
| EA0156 | 50.00 | 3.00 | | 0.405 | | |
| EA0042 | 50.00 | 6.00 | | 0.810 | | |
| EA0234 | 50.00 | 8.00 | | 1.080 | | |
| EA0105 | 50.00 | 10.00 | | 1.350 | | |
| EA0478 | 50.00 | 10.00 | | 1.022 | 5.00 | |
| EA0174 | 50.00 | 20.00 | | 2.700 | | |
| EA0106 | 50.00 | 25.00 | | 3.375 | | |
| EA0417 | 60.00 | 3.00 | | 0.486 | | |
| EA0025 | 60.00 | 6.00 | | 0.972 | | |
| EA0458 | 60.00 | 10.00 | | 1.617 | | 1.00 |
| EA0426 | 80.00 | 1.50 | | 0.323 | | |

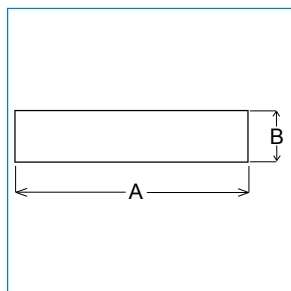

Flat Bar Continued

| Part # | A (mm) | B (mm) | C (mm) | Mass (kg/m) | End Rad. | |
|--------|--------|--------|--------|-------------|----------|--|
| EA0097 | 80.00 | 3.00 | | 0.648 | | |
| EA3153 | 80.00 | 6.00 | | 1.275 | 3.00 | |
| EA0114 | 80.00 | 6.00 | | 1.296 | | |
| EA0076 | 80.00 | 10.00 | | 2.160 | | |
| EA0102 | 80.00 | 12.00 | | 2.592 | | |
| EA0168 | 80.00 | 16.00 | | 3.456 | | |
| EA0107 | 80.00 | 25.00 | | 5.400 | | |
| EA0235 | 89.00 | 6.00 | | 1.442 | | |
| EA0033 | 100.00 | 1.50 | | 0.405 | | |
| EA0108 | 100.00 | 3.00 | | 0.810 | | |
| EA0090 | 100.00 | 6.00 | | 1.620 | | |
| EA0103 | 100.00 | 10.00 | | 2.700 | | |
| EA0173 | 100.00 | 12.00 | | 3.240 | | |
| EA0088 | 100.00 | 25.00 | | 6.750 | | |
| EA0481 | 125.00 | 1.80 | | 0.607 | | |
| EA2802 | 125.00 | 3.00 | | 1.012 | | |
| EA3993 | 140.00 | 20.00 | | 7.557 | 1.00 | |
| EA0476 | 150.00 | 1.80 | | 0.729 | | |
| EA3364 | 150.00 | 4.00 | | 1.620 | | |
| EA0036 | 160.00 | 6.00 | | 2.599 | | |
| EA0104 | 160.00 | 10.00 | | 4.320 | | |

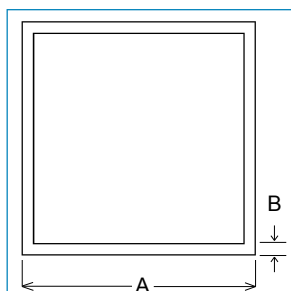

Square Hollow

| Part # | A (mm) | B (mm) | C (mm) | Mass (kg/m) | Int. Rad. | Ext. Rad. |
|--------|--------|--------|--------|-------------|-----------|-----------|
| EA4000 | 19.00 | 1.20 | | 0.231 | | |
| EA0134 | 19.15 | 1.73 | | 0.326 | 1.57 | 1.57 |
| EA3160 | 19.80 | 1.20 | | 0.241 | | |
| EA0450 | 20.00 | 1.20 | | 0.244 | | |
| EA0428 | 20.00 | 1.60 | | 0.318 | | |
| EA0135 | 20.00 | 2.50 | | 0.473 | | |
| EA0233 | 20.00 | 3.00 | | 0.530 | | 3.00 |
| EA0468 | 23.00 | 1.60 | | 0.370 | | |
| EA0063 | 25.00 | 1.60 | | 0.404 | | |
| EA0214 | 25.00 | 1.60 | | 0.390 | | 2.50 |
| EA0079 | 25.00 | 2.00 | | 0.497 | | |
| EA0092 | 25.00 | 3.00 | | 0.713 | | |
| EA0231 | 25.00 | 3.00 | | 0.713 | 3.00 | 3.00 |
| EA0140 | 25.30 | 3.20 | | 0.743 | | 3.00 |
| EA4003 | 25.40 | 1.20 | | 0.314 | | |
| EA0085 | 25.40 | 1.22 | | 0.319 | | |
| EA0443 | 30.00 | 1.60 | | 0.479 | 2.00 | 3.00 |
| EA4063 | 32.00 | 1.20 | | 0.399 | | |
| EA0136 | 32.00 | 3.00 | | 0.940 | | |
| EA0223 | 40.00 | 1.60 | | 0.664 | | |
| EA0253 | 40.00 | 1.60 | | 0.652 | 2.00 | 3.00 |
| EA0137 | 40.00 | 2.50 | | 1.013 | | |
| EA1066 | 40.00 | 3.00 | | 1.199 | | |
| EA0254 | 40.00 | 3.00 | | 1.187 | 2.00 | 3.00 |
| EA0238 | 50.00 | 1.60 | | 0.798 | 4.40 | 6.00 |
| EA0429 | 50.00 | 1.60 | | 0.834 | | 1.00 |
| EA0308 | 50.00 | 2.00 | | 1.037 | | |
| EA0442 | 50.00 | 2.00 | | 0.990 | 4.00 | 6.00 |
| EA0046 | 50.00 | 2.50 | | 1.283 | | |
| EA0138 | 50.00 | 3.00 | | 1.523 | | |
| EA0425 | 50.00 | 3.00 | | 1.460 | 3.00 | 6.00 |

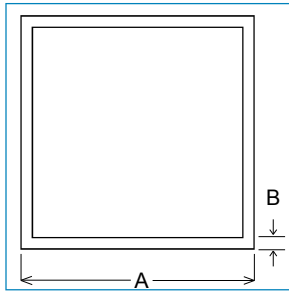

Square Hollow

| Part # | A (mm) | B (mm) | C (mm) | Mass (kg/m) | Int. Rad. | Ext. Rad. |
|--------|--------|--------|--------|-------------|-----------|-----------|
| EA0158 | 50.80 | 1.60 | | 0.812 | 4.40 | 6.00 |
| EA0139 | 65.00 | 1.60 | | 1.096 | | |
| EA0473 | 75.00 | 4.00 | | 3.067 | | |
| EA0145 | 98.00 | 2.50 | | 2.578 | | |
| EA0448 | 100.00 | 3.00 | | 3.143 | | |
| EA0489 | 100.00 | 2.00 | | 2.117 | | |

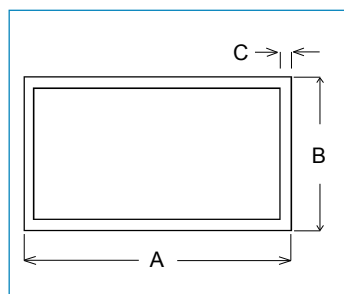

Rectangular Hollow

| Part # | A (mm) | B (mm) | C (mm) | Mass (kg/m) | Int. Rad. | Ext. Rad. |
|--------|--------|--------|--------|-------------|-----------|-----------|
| EA0226 | 25.40 | 19.05 | 1.00 | 0.229 | | |
| EA2417 | 32.00 | 10.00 | 1.40 | 0.296 | | |
| EA0414 | 38.00 | 25.00 | 1.50 | 0.470 | 1.50 | 3.00 |
| EA4064 | 38.00 | 25.00 | 1.60 | 0.516 | | |
| EA0215 | 40.00 | 20.00 | 3.00 | 0.875 | | |
| EA0142 | 40.00 | 25.00 | 2.50 | 0.810 | | |
| EA4007 | 50.00 | 19.00 | 1.20 | 0.432 | | |
| EA4016 | 50.00 | 25.00 | 1.20 | 0.470 | | |
| EA0143 | 50.00 | 25.00 | 2.50 | 0.945 | | |
| EA0095 | 50.00 | 25.00 | 3.00 | 1.118 | | |
| EA0224 | 50.00 | 38.00 | 3.00 | 1.328 | | |
| EA3307 | 50.55 | 10.95 | 1.20 | 0.381 | | 1.00 |
| EA0251 | 60.00 | 20.00 | 1.60 | 0.664 | | |
| EA0171 | 60.00 | 40.00 | 3.00 | 1.523 | | |
| EA0449 | 60.00 | 50.00 | 3.00 | 1.685 | | |
| EA0200 | 65.00 | 16.00 | 1.40 | 0.580 | 2.00 | 3.00 |
| EA0270 | 65.20 | 16.30 | 1.20 | 0.499 | 1.80 | 3.00 |
| EA2281 | 75.00 | 15.00 | 2.00 | 0.929 | | |
| EA0219 | 75.00 | 25.00 | 2.20 | 1.136 | | |
| EA0187 | 75.00 | 50.00 | 3.00 | 1.928 | | |
| EA0210 | 76.00 | 25.00 | 1.50 | 0.794 | | |
| EA0452 | 76.20 | 25.40 | 2.36 | 1.235 | | |
| EA0186 | 76.20 | 38.10 | 3.18 | 1.853 | | |
| EA0067 | 80.00 | 40.00 | 3.00 | 1.847 | | |
| EA0183 | 80.00 | 50.00 | 3.00 | 2.009 | | |
| EA0204 | 82.28 | 28.58 | 2.20 | 1.265 | | |
| EA0071 | 100.00 | 25.00 | 2.50 | 1.620 | | |
| EA0229 | 100.00 | 40.00 | 2.00 | 1.469 | | |
| EA0245 | 100.00 | 50.00 | 1.50 | 1.191 | | |
| EA0141 | 100.00 | 50.00 | 3.00 | 2.333 | | |

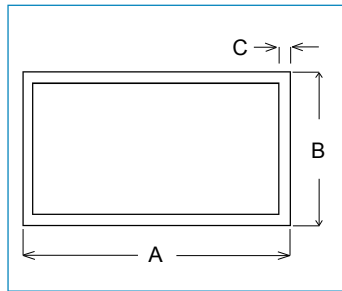

Rectangular Hollow

| Part # | A (mm) | B (mm) | C (mm) | Mass (kg/m) | Int. Rad. | Ext. Rad. |
|--------|--------|--------|--------|-------------|-----------|-----------|
| EA3357 | 100.00 | 50.00 | 3.00 | 2.276 | 3.00 | |
| EA0208 | 125.00 | 50.00 | 3.00 | 2.738 | | |
| EA0228 | 140.00 | 50.00 | 2.20 | 2.205 | | |
| EA2755 | 150.00 | 25.00 | 2.00 | 1.884 | | |
| EA0181 | 150.00 | 50.00 | 3.00 | 3.143 | | |
| EA0463 | 150.00 | 50.00 | 3.00 | 3.094 | 2.00 | 5.00 |
| EA0438 | 150.00 | 75.00 | 3.00 | 3.548 | | |
| EA0157 | 200.00 | 50.00 | 3.00 | 3.953 | | |
| EA0464 | 250.00 | 50.00 | 3.00 | 4.761 | | |

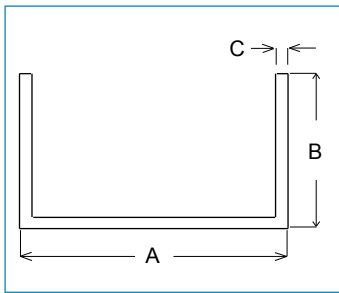

Channel

| Part # | A (mm) | B (mm) | C (mm) | Mass (kg/m) | Int. Rad. | Ext. Rad. |
|--------|--------|---------------|------------|-------------|-----------|-----------|
| EA0078 | 20.00 | 16.00 | 1.60 | 0.211 | | |
| EA0077 | 20.00 | 20.00 | 1.60 | 0.245 | | |
| EA0180 | 20.00 | 20.00 | 3.00 | 0.437 | | |
| EA0034 | 25.00 | 20.00 | 2.50 | 0.405 | | |
| EA0126 | 25.00 | 25.00 | 1.60 | 0.310 | | |
| EA0032 | 25.00 | 25.00 | 3.00 | 0.559 | | |
| EA0129 | 25.00 | 40.00 | 3.00 | 0.802 | | |
| EA0278 | 28.00 | 15.00 | 1.40 | 0.209 | | |
| EA0130 | 32.00 | 25.00 | 3.00 | 0.616 | | |
| EA0431 | 32.00 | 32.00 | 3.00 | 0.729 | | |
| EA0225 | 32.00 | 40.00 | 3.00 | 0.859 | | |
| EA0309 | 34.00 | 50.00 | 5.00 | 1.674 | | |
| EA0131 | 40.00 | 25.00 | 3.00 | 0.681 | | |
| EA0069 | 40.00 | 40.00 | 3.00 | 0.923 | | |
| EA0279 | 40.00 | 60.00 | 3.00 | 1.247 | | |
| EA2007 | 40.00 | 25.00 / 15.00 | 3.00 | 0.599 | | |
| EA1974 | 45.50 | 50.00 | 3.00 | 1.105 | | |
| EA0047 | 49.60 | 66.4 / 43.6 | 1.60 | 0.675 | | |
| EA0080 | 50.00 | 25.00 | 3.00 | 0.761 | | |
| EA0127 | 50.00 | 50.00 | 3.00 | 1.166 | | |
| EA0087 | 60.00 | 32.00 | 3.00 | 0.956 | | |
| EA0066 | 80.00 | 25.00 | 3.00 | 1.005 | | |
| EA0044 | 80.00 | 40.00 | 3.00 | 1.247 | | |
| EA0132 | 80.00 | 40.00 | 4.00 | 1.642 | | |
| EA0099 | 100.00 | 25.00 | 3.00 | 1.166 | | |
| EA0128 | 100.00 | 40.00 | 3.00 | 1.409 | | |
| EA0163 | 100.00 | 40.00 | 4.00 | 1.858 | | |
| EA0198 | 100.00 | 50.00 | 3.00 | 1.571 | | |
| EA3356 | 100.00 | 50.00 | 5.00 | 2.606 | 6.00 | |
| EA0406 | 152.40 | 63.50 | 6.35/7.92 | 5.188 | 10.67 | |
| EA0447 | 177.80 | 76.20 | 6.35/11.10 | 7.407 | 12.20 | |

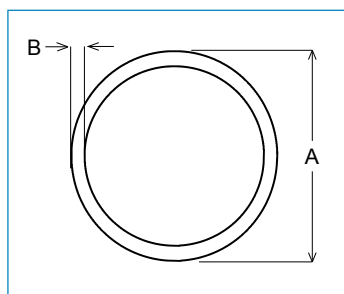

Round Tube

| Part # | A (mm) | B (mm) | C (mm) | Mass (kg/m) | Int. Rad. | Ext. Rad. |
|--------|--------|--------|--------|-------------|-----------|-----------|
| EA0465 | 12.00 | 1.60 | | 0.141 | | |
| EA1013 | 15.90 | 1.40 | | 0.173 | | |
| EA0070 | 16.00 | 1.60 | | 0.195 | | |
| EA0252 | 19.05 | 1.65 | | 0.243 | | |
| EA0081 | 20.00 | 1.60 | | 0.250 | | |
| EA1003 | 25.00 | 1.20 | | 0.243 | | |
| EA1001 | 25.00 | 1.60 | | 0.318 | | |
| EA0062 | 25.00 | 3.00 | | 0.568 | | |
| EA0146 | 32.00 | 1.60 | | 0.413 | | |
| EA0147 | 32.00 | 3.00 | | 0.738 | | |
| EA0471 | 33.40 | 4.00 | | 0.998 | | |
| EA0172 | 38.00 | 2.00 | | 0.611 | | |
| EA0148 | 40.00 | 3.00 | | 0.942 | | |
| EA3800 | 48.40 | 2.60 | | 1.010 | | |
| EA0419 | 48.40 | 3.25 | | 1.245 | | |
| EA0433 | 48.41 | 4.47 | | 1.666 | | |
| EA0155 | 50.00 | 1.60 | | 0.657 | | |
| EA0072 | 50.00 | 3.00 | | 1.196 | | |
| EA0053 | 60.00 | 2.00 | | 0.984 | | |
| EA0418 | 60.00 | 3.00 | | 1.450 | | |
| EA0165 | 60.00 | 5.00 | | 2.333 | | |
| EA0420 | 63.20 | 3.20 | | 1.623 | | |
| EA0310 | 63.50 | 2.60 | | 1.343 | | |
| EA0470 | 63.50 | 3.25 | | 1.661 | | |
| EA0049 | 63.50 | 6.00 | | 2.926 | | |
| EA0462 | 67.00 | 3.00 | | 1.629 | | |
| EA0285 | 76.20 | 2.00 | | 1.259 | | |
| EA0297 | 76.20 | 2.60 | | 1.623 | | |
| EA0421 | 76.20 | 3.20 | | 1.981 | | |
| EA1089 | 76.20 | 3.80 | | 2.334 | | |

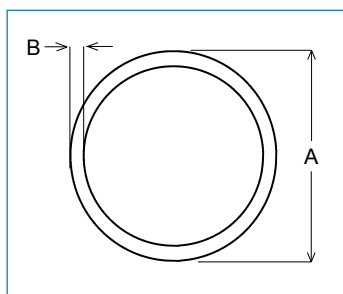

Round Tube

| Part # | A (mm) | B (mm) | C (mm) | Mass (kg/m) | Int. Rad. | Ext. Rad. |
|--------|--------|--------|--------|-------------|-----------|-----------|
| EA0184 | 80.00 | 2.00 | | 1.323 | | |
| EA1901 | 100.40 | 2.30 | | 1.914 | | |
| EA0477 | 101.60 | 3.20 | | 2.670 | | |
| EA0247 | 120.00 | 3.00 | | 2.980 | | |
| EA1902 | 125.00 | 3.00 | | 3.105 | | |
| EA0248 | 140.00 | 3.00 | | 3.486 | | |

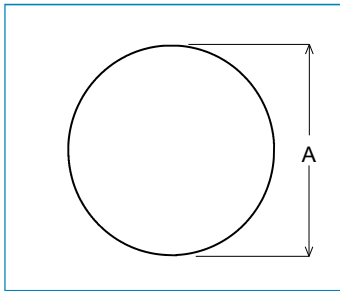

Rod

| Part # | A (mm) | B (mm) | C (mm) | Mass (kg/m) | Int. Rad. | Ext. Rad. |
|--------|--------|--------|--------|-------------|-----------|-----------|
| EA0074 | 8.00 | | | 0.136 | | |
| EA0075 | 10.00 | | | 0.212 | | |
| EA0164 | 18.00 | | | 0.687 | | |

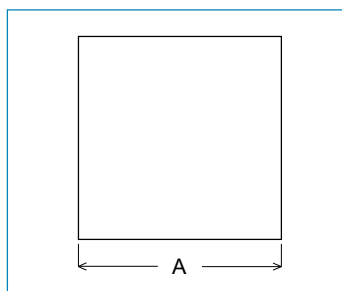

Square Bar

| Part # | A (mm) | B (mm) | C (mm) | Mass (kg/m) | Int. Rad. | Ext. Rad. |
|--------|--------|--------|--------|-------------|-----------|-----------|
| EA0211 | 40.00 | | | 4.320 | | |
| EA0212 | 50.00 | | | 6.750 | | |
| EA0089 | 65.00 | | | 11.408 | | |

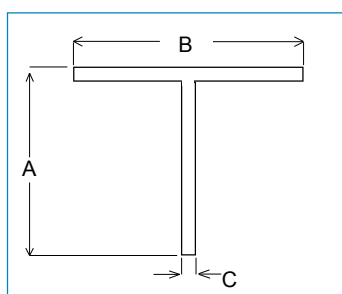

T Section

| Part # | A (mm) | B (mm) | C (mm) | Mass (kg/m) | Int. Rad. | Ext. Rad. |
|--------|--------|--------|--------|-------------|-----------|-----------|
| EA0149 | 20.00 | 20.00 | 3.00 | 0.300 | | |
| EA0474 | 25.00 | 25.00 | 1.50 | 0.196 | | |
| EA0055 | 25.00 | 25.00 | 3.00 | 0.381 | | |
| EA2347 | 30.00 | 60.00 | 8.00 | 1.770 | | |
| EA0150 | 40.00 | 40.00 | 1.60 | 0.339 | | |
| EA0185 | 40.00 | 40.00 | 3.00 | 0.624 | | |
| EA0037 | 44.45 | 38.10 | 1.58 | 0.346 | | |
| EA0298 | 50.00 | 50.00 | 3.00 | 0.785 | | |
| EA2392 | 50.00 | 60.00 | 10.00 | 2.700 | | |
| EA3363 | 50.00 | 100.00 | 6.00 | 2.332 | | |
| EA2346 | 70.00 | 60.00 | 8.00 | 2.634 | | |
| EA0284 | 100.00 | 60.00 | 6.00 | 2.495 | | |
| EA2294 | 150.00 | 180.00 | 5.00 | 4.392 | | |

Adaptor

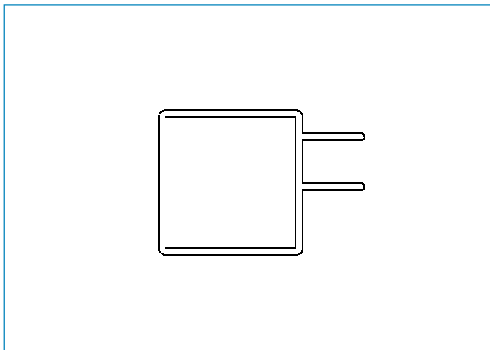

| Part # | A (mm) | B (mm) | Mass (kg/m) |
|--------|--------|--------|-------------|
|--------|--------|--------|-------------|

| | | | |
|--------|-------|------|-------|
| EA0098 | 25.40 | 1.22 | 0.393 |
|--------|-------|------|-------|

Single Rub Rail

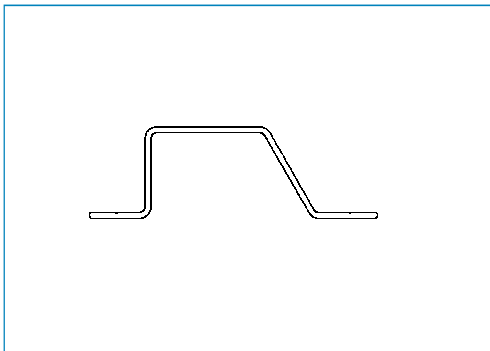

| | | | |
|--------|-------|-------|-------|
| EA0160 | 74.20 | 23.40 | 0.429 |
|--------|-------|-------|-------|

Double Rub Rail

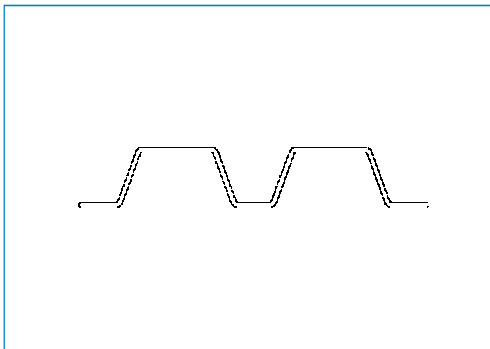

| | | | |
|--------|--------|-------|-------|
| EA0161 | 110.00 | 19.00 | 0.674 |
|--------|--------|-------|-------|

Sign Box

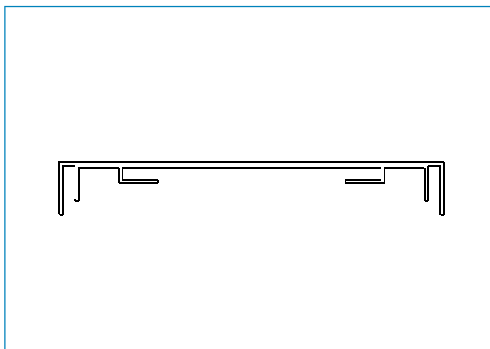

| | | | |
|--------|--------|-------|-------|
| EA0218 | 195.00 | 27.00 | 2.272 |
|--------|--------|-------|-------|

| Part # | A (mm) | B (mm) | Mass (kg/m) |
|--------|--------|--------|-------------|
|--------|--------|--------|-------------|

Slatwall

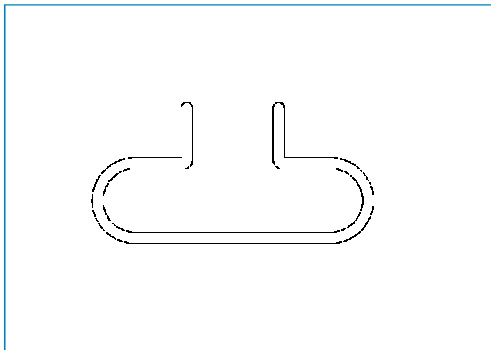

| | | | |
|--------|-------|-------|-------|
| EA0052 | 28.18 | 14.14 | 0.194 |
|--------|-------|-------|-------|

Slatwall

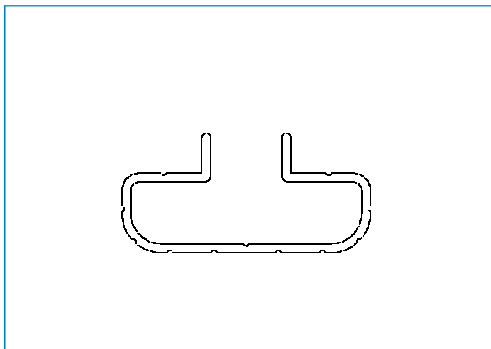

| | | | |
|--------|-------|------|-------|
| EA0220 | 28.00 | 9.00 | 0.174 |
|--------|-------|------|-------|

Base Channel

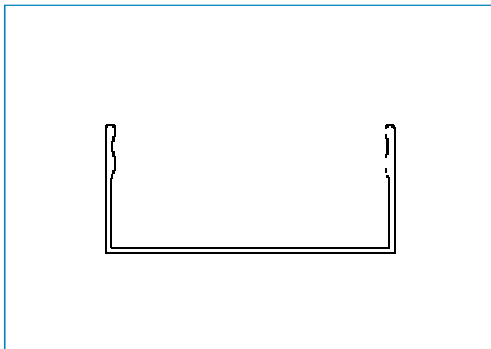

| | | | |
|--------|-------|-------|-------|
| EA0151 | 81.00 | 36.00 | 0.682 |
|--------|-------|-------|-------|

Base Channel

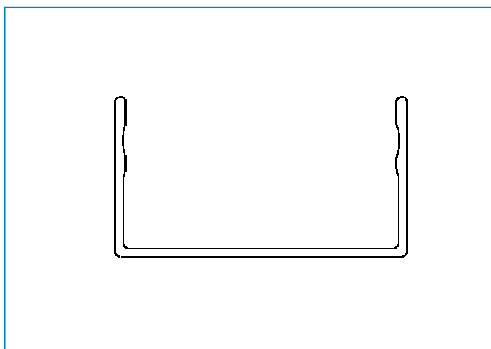

| | | | |
|--------|-------|-------|-------|
| EA0152 | 55.10 | 30.06 | 0.494 |
|--------|-------|-------|-------|

Single Flanged Rope Track

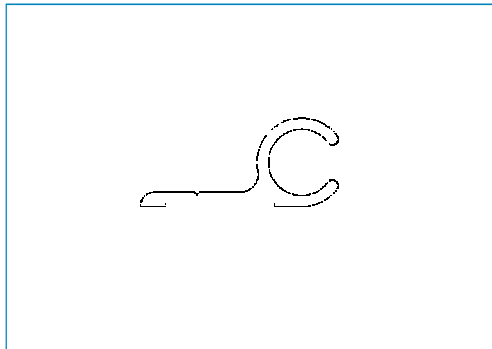

| Part # | A (mm) | B (mm) | Mass (kg/m) |
|--------|--------|--------|-------------|
|--------|--------|--------|-------------|

| | | | |
|--------|-------|-------|-------|
| EA0051 | 28.00 | 12.60 | 0.219 |
|--------|-------|-------|-------|

Double Flanged Rope Track

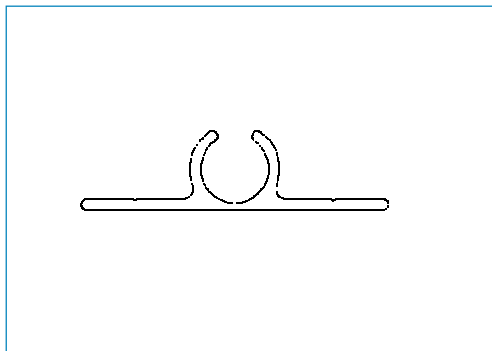

| | | | |
|--------|-------|-------|-------|
| EA0217 | 45.00 | 11.55 | 0.289 |
|--------|-------|-------|-------|

Windscreen Mould

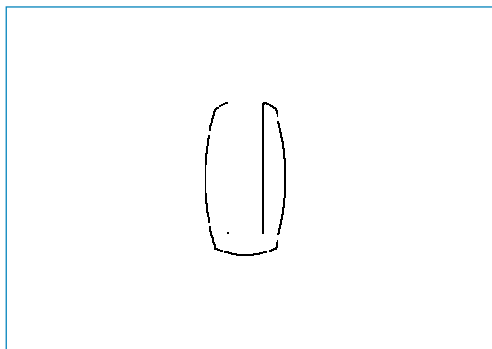

| | | | |
|--------|-------|-------|-------|
| EA0154 | 22.23 | 11.70 | 0.347 |
|--------|-------|-------|-------|

Bullnose Stair Tread

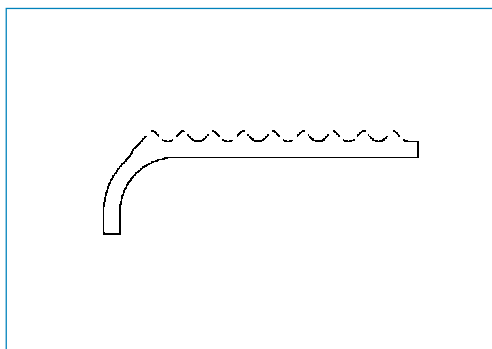

| | | | |
|--------|-------|-------|-------|
| EA0167 | 46.02 | 15.06 | 0.420 |
|--------|-------|-------|-------|

| Part # | A (mm) | B (mm) | Mass (kg/m) |
|--------|--------|--------|-------------|
|--------|--------|--------|-------------|

Stair Tread

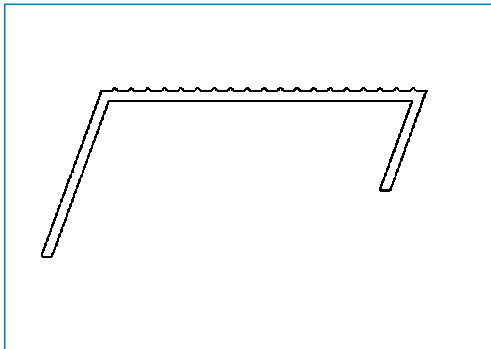

| | | | |
|--------|-------|-------|-------|
| EA2374 | 98.00 | 50.00 | 1.482 |
|--------|-------|-------|-------|

Pit Cover Rail

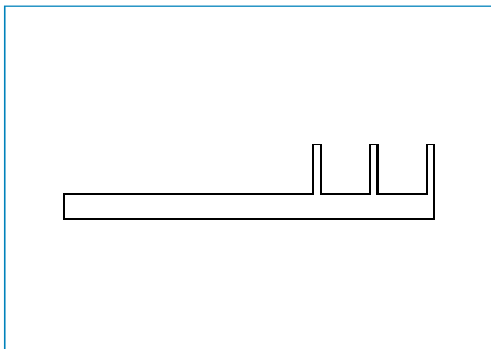

| | | | |
|--------|--------|-------|-------|
| EA1744 | 150.00 | 30.00 | 4.536 |
|--------|--------|-------|-------|

Safety Rail Support

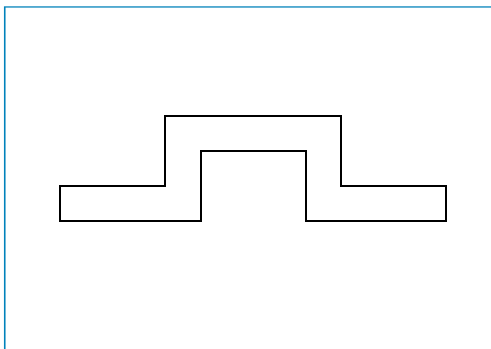

| | | | |
|--------|--------|-------|-------|
| EA1743 | 110.00 | 30.00 | 4.050 |
|--------|--------|-------|-------|

Safety Rail

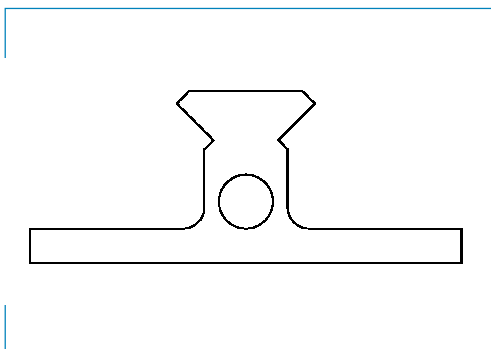

| | | | |
|--------|--------|-------|-------|
| EA1742 | 100.00 | 40.00 | 3.687 |
|--------|--------|-------|-------|

Caravan Angle

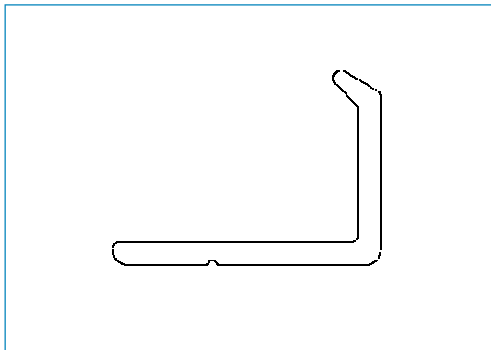

| Part # | A (mm) | B (mm) | Mass (kg/m) |
|--------|--------|--------|-------------|
|--------|--------|--------|-------------|

| | | | |
|--------|-------|-------|-------|
| EA0222 | 17.50 | 12.70 | 0.116 |
|--------|-------|-------|-------|

Caravan Trim—J

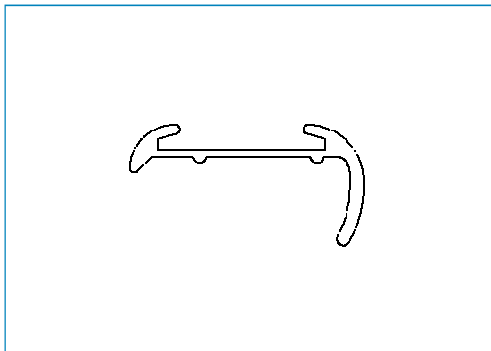

| | | | |
|--------|-------|-------|-------|
| EA0197 | 31.79 | 16.40 | 0.216 |
|--------|-------|-------|-------|

Caravan Trim—Flat

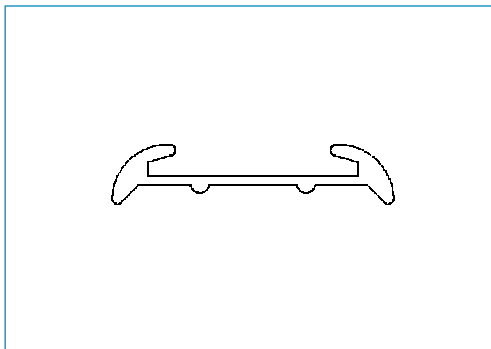

| | | | |
|--------|-------|------|-------|
| EA0221 | 30.50 | 6.40 | 0.161 |
|--------|-------|------|-------|

Racking Material

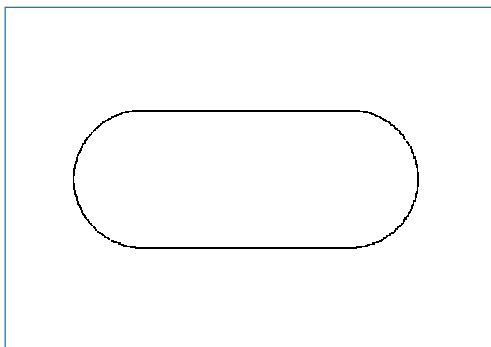

| | | | |
|--------|-------|-------|-------|
| EA0038 | 25.00 | 10.00 | 0.618 |
|--------|-------|-------|-------|

| Part # | A (mm) | B (mm) | Mass (kg/m) |
|--------|--------|--------|-------------|
|--------|--------|--------|-------------|

Racking Material

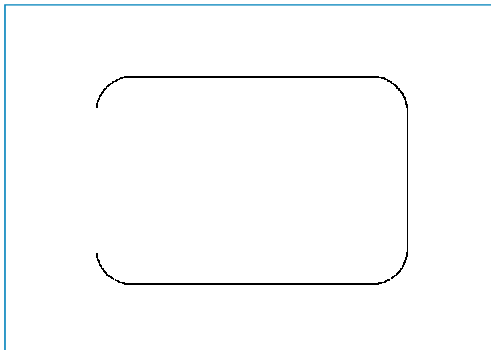

| | | | |
|--------|-------|-------|-------|
| EA0039 | 45.00 | 30.00 | 3.587 |
|--------|-------|-------|-------|

Racking Material

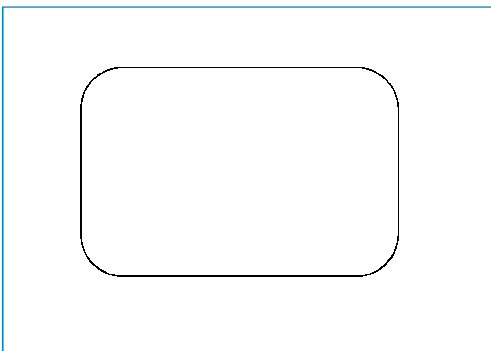

| | | | |
|--------|-------|-------|-------|
| EA0040 | 38.00 | 25.00 | 2.507 |
|--------|-------|-------|-------|

75mm Coving

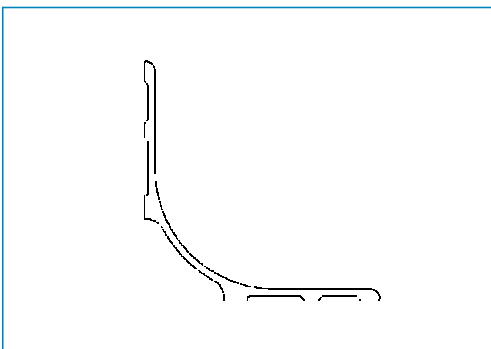

| | | | |
|--------|-------|-------|-------|
| EA0202 | 75.00 | 75.00 | 0.682 |
|--------|-------|-------|-------|

50mm Coving

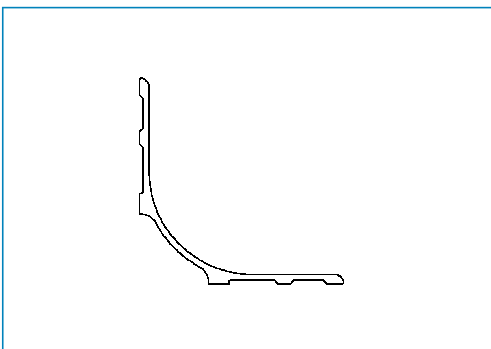

| | | | |
|--------|-------|-------|-------|
| EA0203 | 50.00 | 50.00 | 0.447 |
|--------|-------|-------|-------|

75mm Coolroom Corner

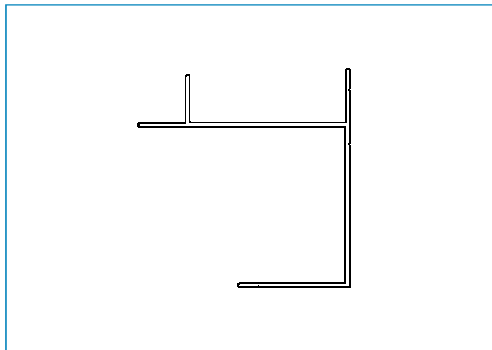

| Part # | A (mm) | B (mm) | Mass (kg/m) |
|--------|--------|--------|-------------|
|--------|--------|--------|-------------|

| | | | |
|--------|-------|--|-------|
| EA0205 | 75.00 | | 1.707 |
|--------|-------|--|-------|

F Section

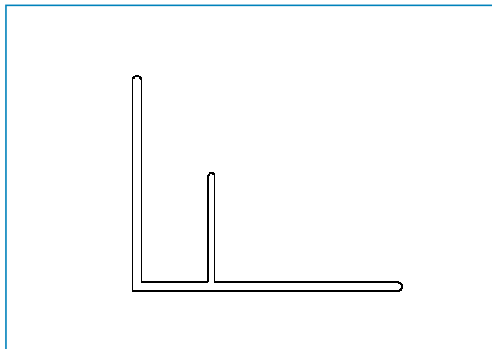

| | | | |
|--------|-------|-------|-------|
| EA0249 | 60.10 | 48.20 | 0.658 |
|--------|-------|-------|-------|

Spectator Seat

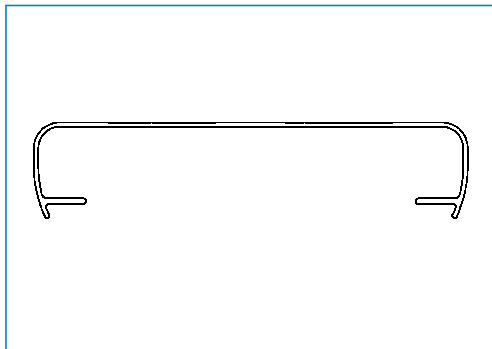

| | | | |
|--------|--------|-------|-------|
| EA0271 | 250.00 | 55.00 | 2.776 |
|--------|--------|-------|-------|

Spectator Seat Back Rest

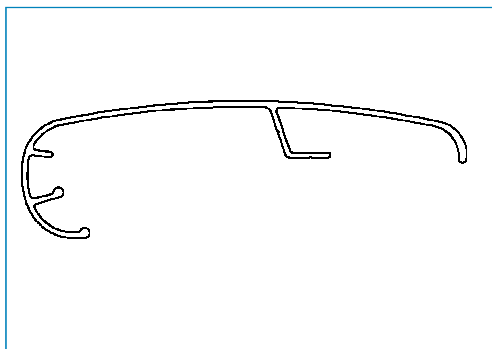

| | | | |
|--------|--------|-------|-------|
| EA0300 | 176.35 | 54.20 | 1.841 |
|--------|--------|-------|-------|

Blinds

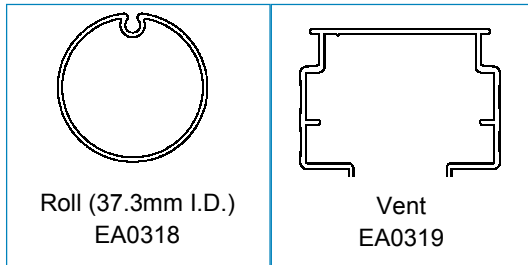

Transport

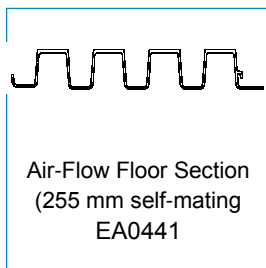



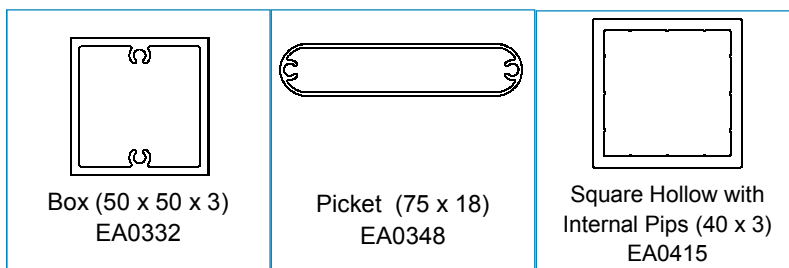

Miscellaneous

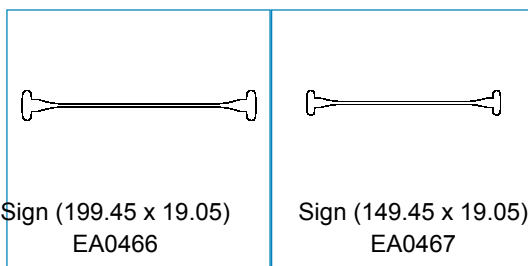

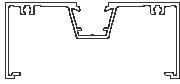

Signs

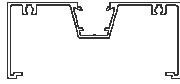



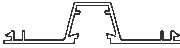

101.6 x 44.4 mm Centre Glazed. Standard Pocket (15mm)

| | | | | |
|-----------------------------------------------------------------------------------|-----------------------------------------------------------------------------------|-----------------------------------------------------------------------------------|-------------------------------------------------------------------------------------|-------------------------------------------------------------------------------------|
|  |  |  |  |  |
| Heavy Frame EA0001 | Standard Frame EA0002 | Light Frame EA0096 | Extra Light Frame EA0003 | Standard Sill/Transom EA0004 |

| | | | | |
|-----------------------------------------------------------------------------------|-----------------------------------------------------------------------------------|-----------------------------------------------------------------------------------|-------------------------------------------------------------------------------------|-------------------------------------------------------------------------------------|
|  |  |  |  |  |
| Heavy Duty Sill/Transom EA0361 | Sill/Transom (Light Weight) EA0410 | Heavy Duty Self- Mating Mullion EA0008 | Self Mating Mullion EA0363 | Heavy Duty Sill EA0015 |

| | | |
|-----------------------------------------------------------------------------------|-----------------------------------------------------------------------------------|-----------------------------------------------------------------------------------|
|  |  |  |
| Glazing Adaptor EA0005 | Light Glazing Adaptor EA0050 | Heavy Duty Glazing Adaptor EA0240 |

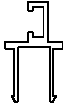
| | | | | |
|-------------------------------------------------------------------------------------|-------------------------------------------------------------------------------------|-------------------------------------------------------------------------------------|---------------------------------------------------------------------------------------|---------------------------------------------------------------------------------------|
|  |  |  |  |  |
| Flat Filler EA0018 | Pocket Filler (18.6mm) EA0408 | Pocket Filler EA0083 | Sill Bead EA0006 | Sloping Sill Bead EA0362 |

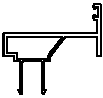
| | | | | |
|-------------------------------------------------------------------------------------|-------------------------------------------------------------------------------------|-------------------------------------------------------------------------------------|---------------------------------------------------------------------------------------|---------------------------------------------------------------------------------------|
|  |  |  |  |  |
| Door Stop EA0007 | Door Stop EA0277 | Door Stop (18.6mm) EA0409 | Door Stop EA0368 | Door Stop EA0423 |

101.6 x 44.4 mm Centre Glazed. Standard Pocket (Continued)

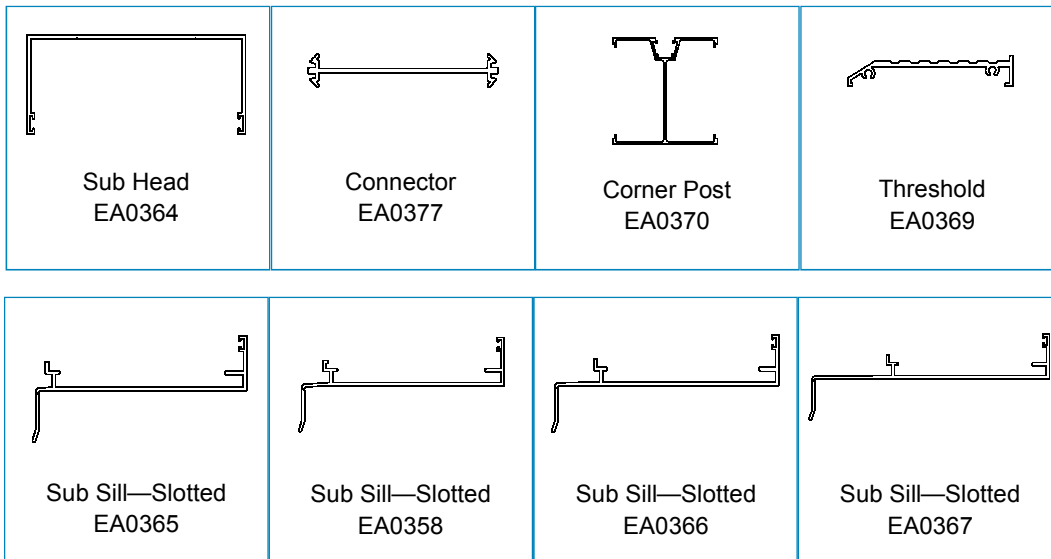

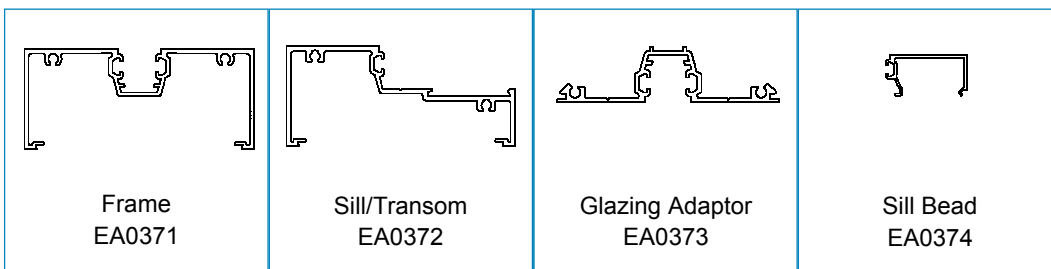

101.6 X 44.4 mm Centre Glazed. Captive Wedge

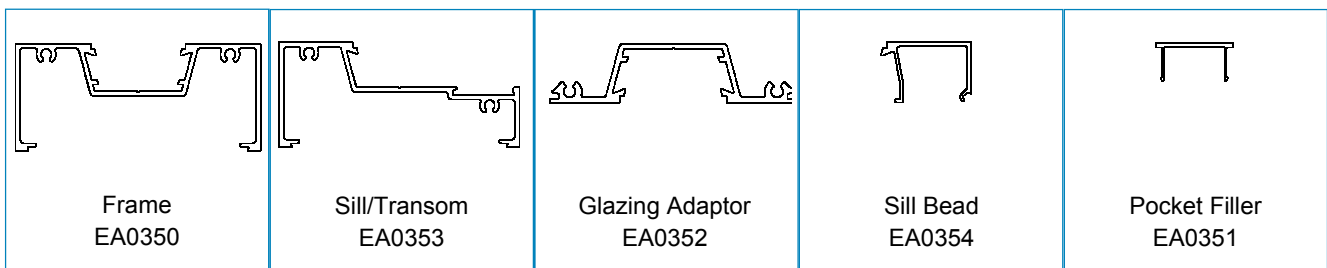

101.6 x 44.4 mm Centre, Double Glazed

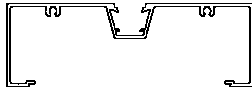
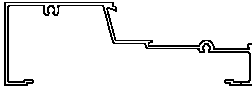
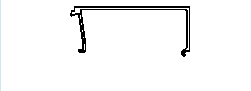
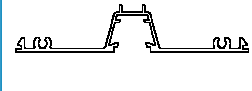
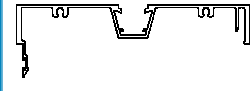

150 x 50 mm Centre Glazed. Standard Pocket

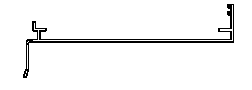
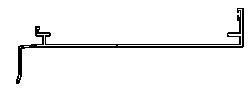
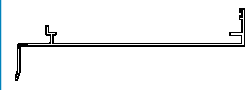
| | | | | |
|--------------------------------------------------------------------------------------------------------------|----------------------------------------------------------------------------------------------------------------------|----------------------------------------------------------------------------------------------------------------------|-----------------------------------------------------------------------------------------------------------------------|---------------------------------------------------------------------------------------------------------------------------|
|  <p>Frame EA0379</p> |  <p>Sill/Transom EA0380</p> |  <p>Sill Bead EA0381</p> |  <p>Glazing Adaptor EA0382</p> |  <p>Self Mating Mullion EA0383</p> |
|  <p>Sub Head EA0424</p> |  <p>Sub Sill—Slotted EA0385</p> |  <p>Sub Sill—Slotted EA0384</p> |  <p>Sub Sill—Slotted EA0378</p> | |

45mm Standard Hinged and Sliding Doors. Single Glazed. Standard 1.8 mm Wall Thickness

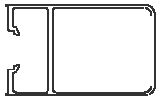
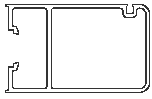
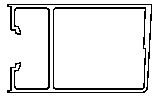
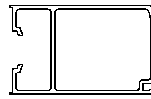
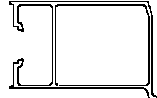
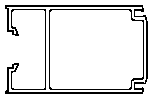
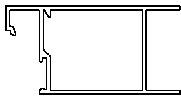
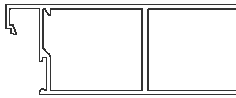
| | | | |
|-------------------------------------------------------------------------------------------------------------------|------------------------------------------------------------------------------------------------------------------------|-----------------------------------------------------------------------------------------------------------------|------------------------------------------------------------------------------------------------------------------|
|  <p>Plain Stile EA0260</p> |  <p>Sliding Door Stile EA0261</p> |  <p>Hinge Stile EA0258</p> |  <p>Lock Stile EA0257</p> |
|  <p>Meeting Stile EA0262</p> |  <p>Weather Stile EA0263</p> |  <p>Top Rail EA0264</p> |  <p>Bottom Rail EA0265</p> |

45mm Standard Hinged and Sliding Doors. Single Glazed. Heavy Duty 2.0 mm Wall Thickness

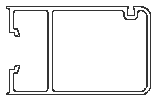
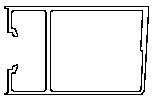
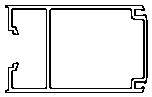
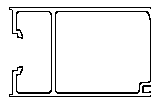
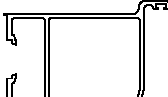
| | | | | |
|--------------------------------------------------------------------------------------------------------------------------|-------------------------------------------------------------------------------------------------------------------|---------------------------------------------------------------------------------------------------------------------|-------------------------------------------------------------------------------------------------------------------|---------------------------------------------------------------------------------------------------------------------------|
|  <p>Sliding Door Stile EA0314</p> |  <p>Hinge Stile EA0289</p> |  <p>Weather Stile EA0398</p> |  <p>Lock Stile EA0388</p> |  <p>Double Door Stile EA0290</p> |
|--------------------------------------------------------------------------------------------------------------------------|-------------------------------------------------------------------------------------------------------------------|---------------------------------------------------------------------------------------------------------------------|-------------------------------------------------------------------------------------------------------------------|---------------------------------------------------------------------------------------------------------------------------|

45mm Standard Hinged and Sliding Doors. Single Glazed. Extra Heavy Duty 2.2 mm Wall Thickness

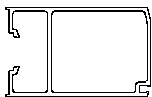
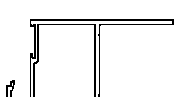
| | | |
|-------------------------------------------------------------------------------------------------------------------|------------------------------------------------------------------------------------------------------------------|-----------------------------------------------------------------------------------------------------------------|
|  <p>Plain Stile EA0411</p> |  <p>Lock Stile EA0288</p> |  <p>Door Rail EA0291</p> |
|-------------------------------------------------------------------------------------------------------------------|------------------------------------------------------------------------------------------------------------------|-----------------------------------------------------------------------------------------------------------------|

45mm Standard Hinged and Sliding Doors (Continued)

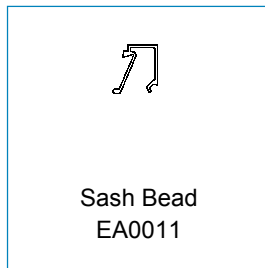

45mm Hinged and Sliding Doors. Single Glazed

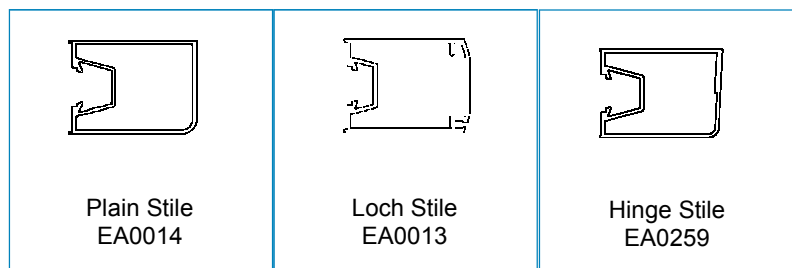

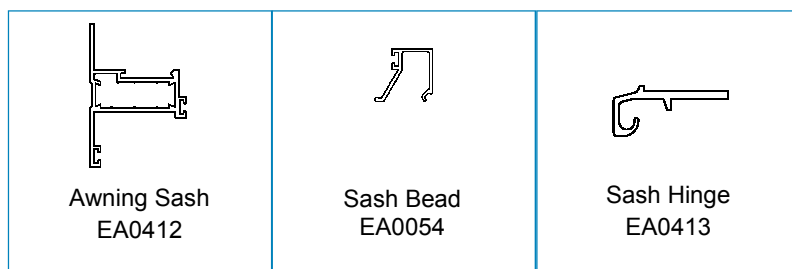

35mm Awning Sash



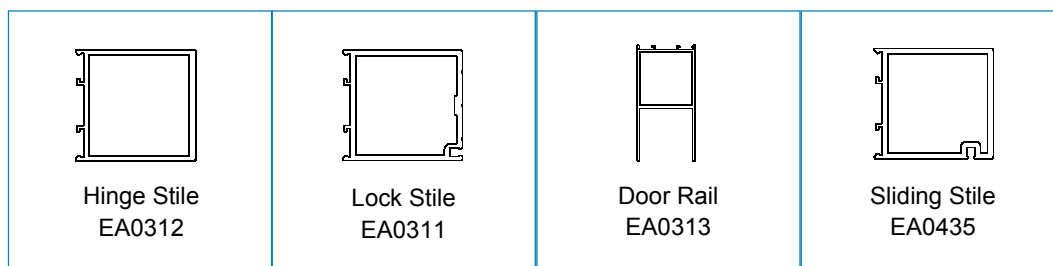

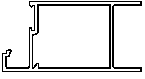
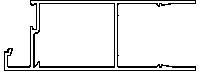

Double Beaded Doors

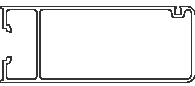

400 Series Door Suite, Single Glazed

| | | |
|-----------------------------------------------------------------------------------|-----------------------------------------------------------------------------------|-----------------------------------------------------------------------------------|
|  |  |  |
| Top Rail EA0009 | Bottom Rail EA0010 | Mid Rail EA0012 |

Wide Hinged and Sliding Doors. Single Glazed

| | | | | |
|-----------------------------------------------------------------------------------|-----------------------------------------------------------------------------------|-----------------------------------------------------------------------------------|------------------------------------------------------------------------------------|-------------------------------------------------------------------------------------|
|  |  |  |  |  |
| Sliding Stile EA0266 | Hinge Stile EA0267 | Lock Stile EA0268 | Pivot Stile EA0269 | Bottom Rail EA0265 |



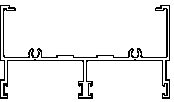
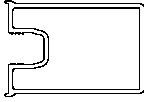
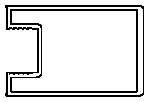
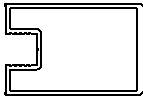
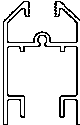

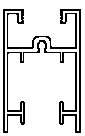
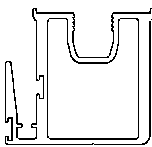
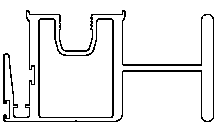
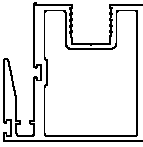
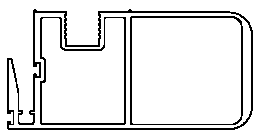
Apartment Door Suite

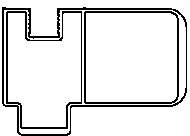
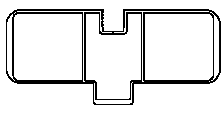
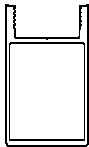
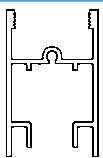
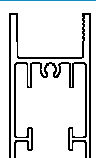
| | | | | |
|-------------------------------------------------------------------------------------|-------------------------------------------------------------------------------------|-------------------------------------------------------------------------------------|--------------------------------------------------------------------------------------|---------------------------------------------------------------------------------------|
|  |  |  |  |  |
| Head/Jamb EA1004 (101.6mm suites) | Plain Stile EA1006 | Plain Stile (Thick Glass) EA0430 | Plain Stile EA0394 | Door Rail EA1005 |



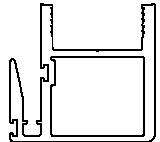
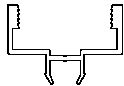
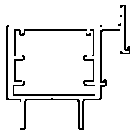
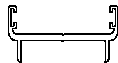
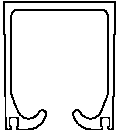

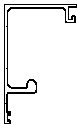
| | | | | |
|-------------------------------------------------------------------------------------|-------------------------------------------------------------------------------------|-------------------------------------------------------------------------------------|--------------------------------------------------------------------------------------|---------------------------------------------------------------------------------------|
|  |  |  |  |  |
| Door Rail EA0399 | Interlock EA1007 | Interlock EA1008 | Interlock EA0395 | Interlock EA0396 |

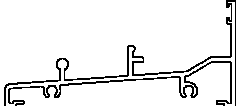
| | | | | |
|-------------------------------------------------------------------------------------|-------------------------------------------------------------------------------------|-------------------------------------------------------------------------------------|--------------------------------------------------------------------------------------|---------------------------------------------------------------------------------------|
|  |  |  |  |  |
| Handle EA0397 | Handle EA0387 | Plain Double Glaze Stile EA0274 | Double Glaze DoorRail EA1010 | Double Glaze Door Rail EA0276 |

Apartment Door Suite (Continued)

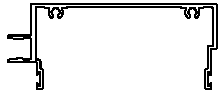

| | | | | |
|----------------------------------------------------------------------------------------------------------------------------|--------------------------------------------------------------------------------------------------------------------------|------------------------------------------------------------------------------------------------------------------------------------|--------------------------------------------------------------------------------------------------------------------|---------------------------------------------------------------------------------------------------------------------------|
|  <p>Double Glaze Interlock EA0275</p> |  <p>Double Glaze Adaptor EA1009</p> |  <p>Adaptor EA1011</p> |  <p>Adaptor EA1012</p> |  <p>Overhead Door Track EA0391</p> |
|  <p>Plant-on Door Stop EA0316</p> |  <p>Top Track EA0315</p> |  <p>Overhead Door Track Pelmet EA0392</p> |  <p>Bottom Guide EA0272</p> |  <p>Sill—Slotted EA0359</p> |

103.6 x 50mm Front Glazed. Single Glazed Capped

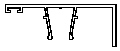
| | | | | |
|---------------------------------------------------------------------------------------------------------------|------------------------------------------------------------------------------------------------------------------------|--------------------------------------------------------------------------------------------------------------------------|--------------------------------------------------------------------------------------------------------------|------------------------------------------------------------------------------------------------------------------|
|  <p>Head/Jamb EA0201</p> |  <p>Male Split Mullion EA0019</p> |  <p>Female Split Mullion EA0020</p> |  <p>Adaptor EA0021</p> |  <p>Snap Cover EA0022</p> |
|---------------------------------------------------------------------------------------------------------------|------------------------------------------------------------------------------------------------------------------------|--------------------------------------------------------------------------------------------------------------------------|--------------------------------------------------------------------------------------------------------------|------------------------------------------------------------------------------------------------------------------|



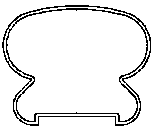
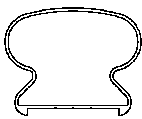
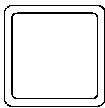
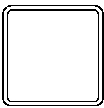

| |
|----------------------------------------------------------------------------------------------------------------|
|  <p>Snap Cover EA0023</p> |
|----------------------------------------------------------------------------------------------------------------|

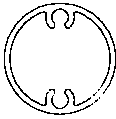
Ballustrade

| | | | | |
|----------------------------------------------------------------------------------------------------------------|-----------------------------------------------------------------------------------------------------------------------|--------------------------------------------------------------------------------------------------------------------------|---------------------------------------------------------------------------------------------------------------------------|----------------------------------------------------------------------------------------------------------------------|
|  <p>Handrail EA0256</p> |  <p>Handrail Insert EA0255</p> |  <p>Fence Rail (Heavy) EA0254</p> |  <p>Fence Rail (Light) EA0253</p> |  <p>Round Picket EA0252</p> |
|----------------------------------------------------------------------------------------------------------------|-----------------------------------------------------------------------------------------------------------------------|--------------------------------------------------------------------------------------------------------------------------|---------------------------------------------------------------------------------------------------------------------------|----------------------------------------------------------------------------------------------------------------------|

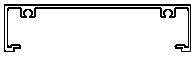
| |
|----------------------------------------------------------------------------------------------------------------|
|  <p>Baluster EA0317</p> |
|----------------------------------------------------------------------------------------------------------------|

Other Frames

| | | | |
|------------------------------------------------------------------------------------------------------------------------|------------------------------------------------------------------------------------------------------------------------|----------------------------------------------------------------------------------------------------------------------|------------------------------------------------------------------------------------------------------------------------------------------|
|  <p>Open Box(101.6x25) EA0375</p> |  <p>Open Box(101.6x50) EA0376</p> |  <p>Open Box(150x50) EA0386</p> |  <p>Narrow Frame (101.6 x 25.4 mm) EA0016</p> |
|------------------------------------------------------------------------------------------------------------------------|------------------------------------------------------------------------------------------------------------------------|----------------------------------------------------------------------------------------------------------------------|------------------------------------------------------------------------------------------------------------------------------------------|

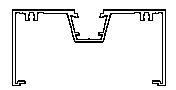
| | |
|-----------------------------------------------------------------------------------------------------------------------------------------|-------------------------------------------------------------------------------------------------------------------------------|
|  <p>Frame Heavy Duty (101.6 x 25mm) EA0360</p> |  <p>Frame (101.6 x 50 mm) EA0084</p> |
|-----------------------------------------------------------------------------------------------------------------------------------------|-------------------------------------------------------------------------------------------------------------------------------|

Security Doors

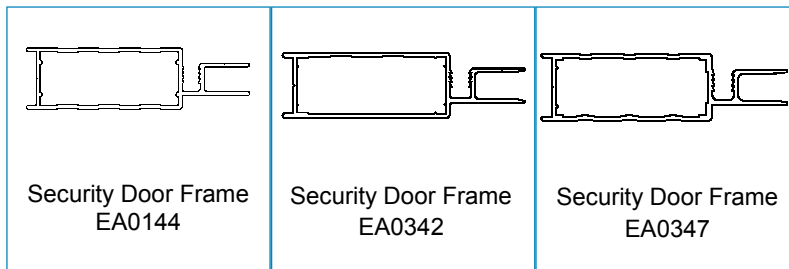

Security Windows

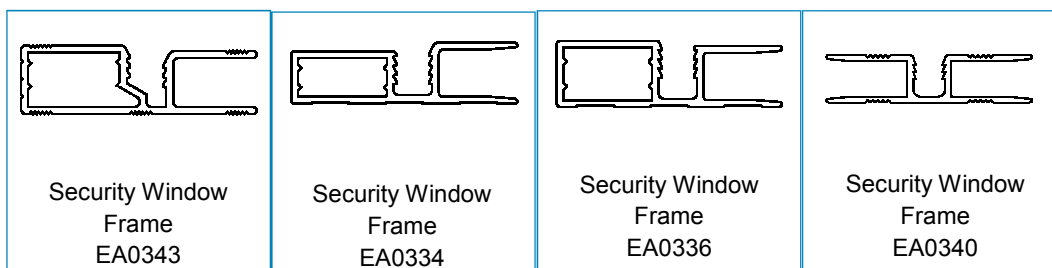

Interlock, Track, Overlap

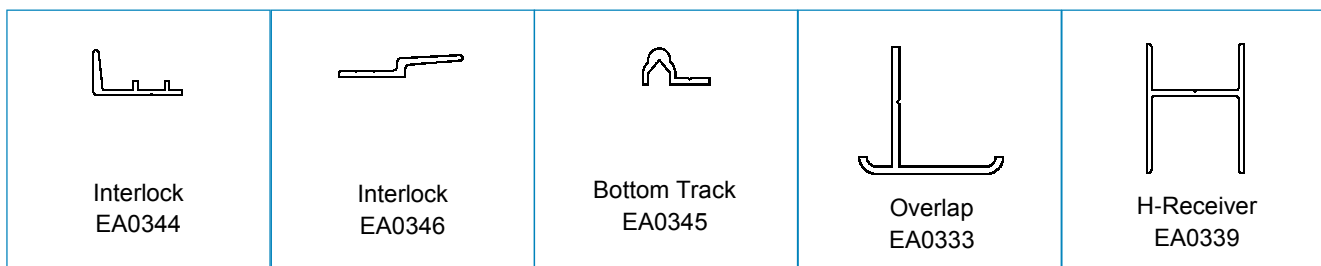

Corner Stakes

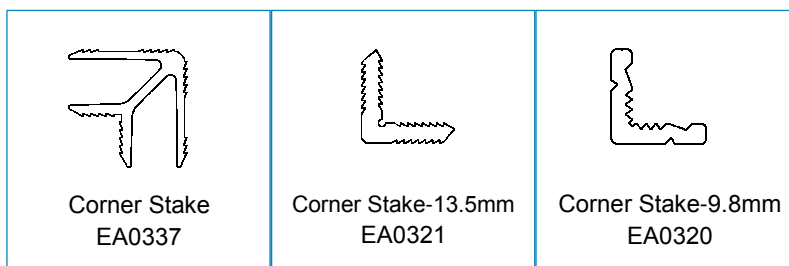

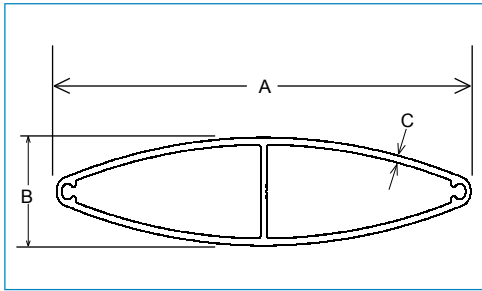

Elliptical Louvre

| Part # | A (mm) | B (mm) | C (mm) | Mass (kg/m) |
|--------|--------|--------|--------|-------------|
| EA0301 | 70.00 | 10.00 | 1.20 | .456 |
| EA2759 | 80.00 | 12.60 | 1.20 | 0.585 |
| EA0299 | 150.00 | 23.00 | 1.60 | 1.638 |
| EA0302 | 150.00 | 30.00 | 2.00 | 1.828 |
| EA0303 | 175.00 | 35.00 | 2.00 | 2.130 |

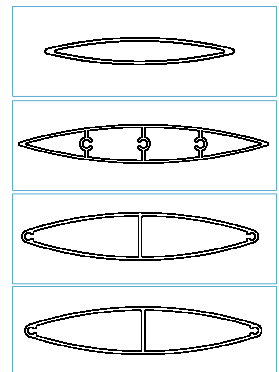

Louvre Blade

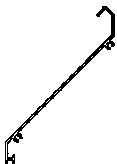
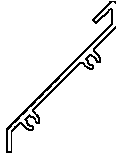
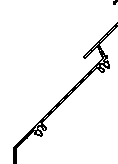
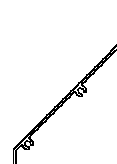
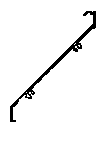
| | | | | |
|------------------------------------------------------------------------------------------------------------------------|-----------------------------------------------------------------------------------------------------------------------|-------------------------------------------------------------------------------------------------------------------------|--------------------------------------------------------------------------------------------------------------------------|--------------------------------------------------------------------------------------------------------------------------|
|  <p>Blade (90 x 130) EA0326</p> |  <p>Blade (46 x 63) EA0327</p> |  <p>Blade (115 x 130) EA0328</p> |  <p>Blade (90 x 110) EA0329</p> |  <p>Blade (115 x 88) EA0330</p> |
|------------------------------------------------------------------------------------------------------------------------|-----------------------------------------------------------------------------------------------------------------------|-------------------------------------------------------------------------------------------------------------------------|--------------------------------------------------------------------------------------------------------------------------|--------------------------------------------------------------------------------------------------------------------------|

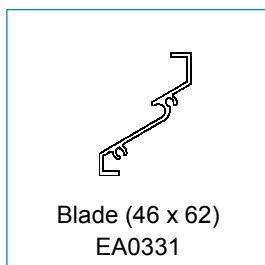

Angle

| Part # | A (mm) | B (mm) | C (mm) | Mass (kg/m) | Int. Rad. | Ext. Rad. |
|--------|--------|--------|--------|-------------|-----------|-----------|
| EA2655 | 20.00 | 6.00 | 1.60 | 0.105 | | |
| EA3316 | 30.00 | 30.00 | 1.60 | 0.252 | | |
| EA0483 | 35.00 | 35.00 | 1.60 | 0.295 | | |
| EA3269 | 47.00 | 32.00 | 3.00 | 0.615 | | |
| EA2858 | 75.00 | 35.00 | 3.00 | 0.866 | | |
| EA2782 | 75.00 | 75.00 | 2.5 | 0.995 | | |
| EA0475 | 100.00 | 50.00 | 3.00 | 1.190 | | |
| EA0484 | 100.00 | 50.00 | 6.00 | 2.332 | | |

Flat Bar

| Part # | A (mm) | B (mm) | C (mm) | Mass (kg/m) | Int. Rad. | Ext. Rad. |
|--------|--------|--------|--------|-------------|-----------|-----------|
| EA0458 | 60.00 | 10.00 | | 1.617 | | 1.00 |
| EA0481 | 125.00 | 1.80 | | 0.607 | | |
| EA2802 | 125.00 | 3.00 | | 1.012 | | |
| EA0476 | 150.00 | 1.80 | | 0.729 | | |
| EA3364 | 150.00 | 4.00 | | 7.557 | | |
| EA0036 | 160.00 | 6.00 | | 2.599 | | |

Square Hollow

| Part # | A (mm) | B (mm) | C (mm) | Mass (kg/m) | Int. Rad. | Ext. Rad. |
|--------|--------|--------|--------|-------------|-----------|-----------|
| EA4000 | 19.00 | 1.20 | | 0.231 | | |
| EA4003 | 25.40 | 1.20 | | 0.314 | | |
| EA4063 | 32.00 | 1.20 | | 0.399 | | |
| EA0473 | 75.00 | 4.00 | | 3.067 | | |
| EA0489 | 100.00 | 2.00 | | 2.117 | | |

Channel

| Part # | A (mm) | B (mm) | C (mm) | Mass (kg/m) | Int. Rad. | Ext. Rad. |
|--------|--------|--------|--------|-------------|-----------|-----------|
| EA1974 | 42.50 | 50.00 | 3.00 | 1.105 | | |

Rectangular Hollow

| Part # | A (mm) | B (mm) | C (mm) | Mass (kg/m) | Int. Rad. | Ext. Rad. |
|--------|--------|--------|--------|-------------|-----------|-----------|
| EA2417 | 32.00 | 10.00 | 1.40 | 0.296 | | |
| EA4064 | 38.00 | 25.00 | 1.60 | 0.516 | | |
| EA4007 | 50.00 | 19.00 | 1.20 | 0.432 | | |
| EA4016 | 50.00 | 25.00 | 1.20 | 0.470 | | |
| EA2281 | 75.00 | 15.00 | 2.00 | 0.929 | | |
| EA3357 | 100.00 | 50.00 | 3.00 | 2.276 | | |
| EA2755 | 150.00 | 25.00 | 2.00 | 1.884 | | |
| EA0463 | 150.00 | 50.00 | 3.00 | 3.094 | 2.00 | 5.00 |
| EA0464 | 250.00 | 50.00 | 3.00 | 4.761 | | |

Round Tube

| Part # | A (mm) | B (mm) | C (mm) | Mass (kg/m) | Int. Rad. | Ext. Rad. |
|--------|--------|--------|--------|-------------|-----------|-----------|
| EA3800 | 48.40 | 2.60 | | 1.010 | | |
| EA0477 | 101.60 | 3.20 | | 2.670 | | |

T-Section

| Part # | A (mm) | B (mm) | C (mm) | Mass (kg/m) | Int. Rad. | Ext. Rad. |
|--------|--------|--------|--------|-------------|-----------|-----------|
| EA0474 | 25.00 | 25.00 | 1.50 | 0.196 | | |
| EA2347 | 30.00 | 60.00 | 8.00 | 1.770 | | |
| EA2392 | 50.00 | 60.00 | 10.00 | 2.700 | | |
| EA3363 | 50.00 | 100.00 | 6.00 | 2.332 | | |
| EA2346 | 70.00 | 60.00 | 8.00 | 2.634 | | |
| EA2294 | 150.00 | 180.00 | 5.00 | 4.392 | | |

Elliptical Louvre

| Part # | A (mm) | B (mm) | C (mm) | Mass (kg/m) | Int. Rad. | Ext. Rad. |
|--------|--------|--------|--------|-------------|-----------|-----------|
| EA2759 | 80.00 | 12.60 | 1.20 | 0.585 | | |